



ATOSA Catering Equipment INC.



WE MAKE THE KITCHEN BETTER





ATOSA CATERING EQUIPMENT INC.

WE MAKE THE KITCHEN BETTER

Toll Free: 855-855-0399 Email: info@atosausa.com

www.atosa.com | www.atosausa.com

California, Colorado, Florida, Georgia, Illinois, Massachusetts, New Jersey, Ohio, Texas, Washington



Warehouse in The USA



California Headquarters

1225 W. Imperial Hwy,
Brea, CA 92821

Tel: (909)-595-2688
Fax: (909)-595-7688
Email: social@atosausa.com

Arlington, TX

407113th StreetArlington,
TX 76011

Tel: (817)-385-0890
Fax: (817)-385-0894
Email: dallas@atosausa.com

Atlanta, GA

7575-A Ponce De Leon Circle Doraville ·
GA30340

Tel: (770)-248-9797
Fax: (770)-248-9799
Email: atlanta@atosausa.com

Boston, MA

203 Flanders Rd. Westborough,
MA01581

Tel: (508)-329-6031
Fax: (508)-329-6030
Email: boston@atosausa.com

Denver, CO

2250 N. Airport Boulevard
Suite 500 Aurora, CO 80011

Tel: (303)-577-0061
Fax: (303) 577-0314
Email: denver@atosausa.com

Hayward, CA

26545 Danti Court Hayward,
CA94545

Tel: (510)-670-2951
Fax: (510)-670-2950
Email: sf@atosausa.com

Homer Glen, IL

14503 Gougar Rd. Suite 7 Homer Glen ·
IL 60491

Tel: (815)-838-9503
Fax: (815)-838-9504
Email: chicago@atosausa.com

Houston, TX

16420 West Hardy Rd.,
Suite 245 Houston, TX 77060

Tel: (281)-877-0200
Fax: (281)-877-4165
Email: houston@atosausa.com

Kent, WA

6930 South 212th StreetKent ·
WA98032

Tel: (253)-236-5295
Fax: (844)-585-7245
Email: seattle@atosausa.com

Lakeland, FL

3010 Maine Ave. #7 Lakeland ·
FL33801

Tel: (863)-698-7905
Fax: (863)-698-7906
Email: orlando@atosausa.com

Fairfield, NJ

12 Gardner Rd. Fairfield ·
NJ 07004

Tel: (201)-355-8257
Fax: (201)-355-8810
Email: nj@atosausa.com

Groveport, OH

5700 North Green Pointe Drive
Suite C Groveport, OH 43125

Tel: (614)-648-5313
Fax: (614)-567-6163
Email: ohio@atosausa.com



ATOSA CATERING EQUIPMENT INC.

Smart Kitchen Service

Dear Atosa User:

We are incredibly proud to announce our very own in-house service department. At Smart Kitchen Service, our staff is dedicated to providing our customers with services and products exceeding their expectations. At Smart Kitchen Service, we pride ourselves on delivering superior customer service by providing a steady communication between our service agents and our customers. Our unique ability to provide customers with same day customers service, gives us an edge over our competition. At Smart Kitchen Service every one of our customers is assigned to a specific customer service representative, who directly oversees every service call and its progress from start to finish. The direct involvement of our customer service team allows Smart Kitchen Service to remain flexible and tailor our service to suit the needs of our customers. When you need a solution our customer service representatives are there to help you find it. We make your satisfaction and continued business our priority!

Our service director has a life time experience. He has spent a career in commercial food service manufacturing roles. He began as a quality control engineer, and was promoted to a director of product quality and product services, and he has personally trained each one of our service agents individually, to make sure we provide you with the ultimate customer service experience.

We will not rest, until our customers are 100% satisfied.

Toll Free: 800-683-8660

East Coast Service Representative:
Ext. 104 & Ext. 109

West Coast Service Representative:
Ext. 103& Ext. 110

Central Service Representative:
Ext. 105& Ext. 108



ATOSACATERING EQUIPMENT INC.

Contents

REFRIGERATION

Upright Freezer - Top Mount Series	01
Upright Refrigerator - Top Mount Series	03
Upright Freezer - Bottom Mount Series	05
Upright Refrigerator - Bottom Mount Series	07
Glass Door Merchandiser - Freezer Series	09
Glass Door Merchandiser - Refrigerator Series	11
Undercounter Refrigerator Series	13
Undercounter Freezer Series	15
Sandwich Prep Table Refrigerator Series	17
Mega Top Sandwich Prep Table Refrigerator Series	19
Pizza Prep Table Refrigerator Series	21
ChefBase	23

GAS EQUIPMENTS

Char Rock Broilers	25
Radiant Broilers	27
Griddles	29
Hot Plates	31
Stock Pot Stoves	33
Fryers	35

SMALLWARES

Economic Chafers	37
Roll Top Chafers	39
Food Warmers	41
Stainless Steel Equipment Stands	43
Steam Table Pans	45

SINKS & TABLES

Work Tables 24 inch Series	47
Work Tables 30 inch Series	48
Compartment Sinks MRSA-1-D	49
Compartment Sinks MRSA-1-L	50
Compartment Sinks MRS-1-MOP	51
Compartment Sinks MRSA-1-N	52
Compartment Sinks MRSA-1-R	53
Compartment Sinks MRSB-3-D/MRSA-3-D	54
Welding Hand Wash Sinks MRS-HS-14	55
Welding Hand Wash Sinks MRS-HS-18	56



ATOSA CATERING EQUIPMENT INC.



REFRIGERATION

Upright Freezer- Top Mount Series	01
Upright Refrigerator - Top Mount Series	03
Upright Freezer- Bottom Mount Series	05
Upright Refrigerator - Bottom Mount Series	07
Glass Door Merchandiser - Freezer Series	09
Glass Door Merchandiser - Refrigerator Series	11
Undercounter Refrigerator Series	13
Undercounter Freezer Series	15
Sandwich Prep Table Refrigerator Series	17
Mega Top Sandwich Prep Table Refrigerator Series	19
Pizza Prep Table Refrigerator Series	21
Chef Base	23



ATOSACATERING EQUIPMENT INC.

WE ARE THE SPECICOOOLIST!

Toll Free:855-855-0399 Email:info@atosausa.com
 www.atosa.com | www.atosausa.com
 California,Colorado,Florida,Georgia, Illinois,Massachusetts,New Jersey,Ohio,Texas,
 Washington

Upright Freezer-Top Mount Series

Standard Features

- Top mount compressor units
- Exterior & interior stainless steel construction
- Dixell digital temperature control system
- Heavy duty Embraco compressor
- Self-closing and stay open door
- Efficient refrigeration system
- Round comer design
- Recessed door handle
- Standard safety door lock
- Magnetic door gaskets
- Pre-installed castors
- Pre-installed shelves
- 155lbs loading capacity per shelf

MBF8001



MBF8002



MBF8003



Specifications

Model	Doors	Cu.Ft	Shelves	Exterior Dimensions(W*D*H)	Packing Dimensions(W*D*H)	Castors	Gross Weight(LBS)	HP	Voltage	Amps	Refrigerant
MBF8001	1	22.6	3	28.74 X 33.27 X 82.89	30.4X34.7X85.8	4inch	278.96	1/2	115/60/1	7.5	R-404a
MBF8002	2	44.5	6	51.73X33.27X82.89	54.5X34.7X85.8	4inch	413.16	3/4	115/60/1	12	R-404a
MBF8003	3	69.2	9	77.8 X 33.27 X 82.89	80.7X34.7X85.8	4inch	574.64	1	115/208-230/60/1	5.5	R-404a

For best results of food presevation, we recommend setting your freezer between 0°F - 8°F



2 YEARS WARRANIYON ALLPAITTSAND LABOR(US ONLY)
 5 YEARS WARRANTY ON ffIMPRESSOR(US ONLY)



1. Don't forget to leave the unit some room to breathe!
2. Please clean the condenser frequently to give the unit more fresh air.



Plan View

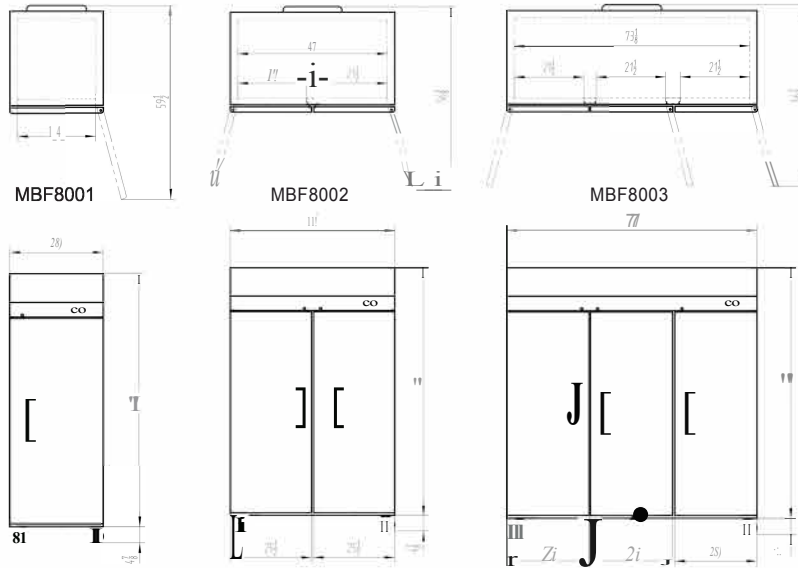

Side View

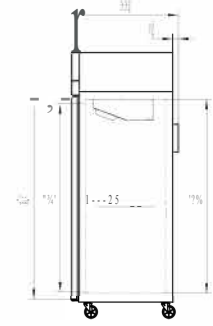

Terms and Conditions

2 YEAR WARRANTY

All claims for parts or labor must be made directly through Atosa. All claims must include: model number of the unit, the serial number, proof of purchase, date of installation, and all pertinent information supporting the alleged defect. In case of compressor replacement under warranty, either compressor or compressor tag must be returned to Alosa along with above listed information. **Failure to comply with warranty policies will result in voiding claims.**

Two Year Parts & Labor Warranty

Atosa warrants all new refrigerated components, such as the cabinet and all parts, to be free from defects in materials or workmanship. Atosa's obligation under this warranty is limited to a period of two (2) years from the date of original installation or 27 months after shipment date from Alosa, whichever occurs first. All parts covered under this warranty that are defective within two (2) years of original installation or twenty seven (27) months after shipment date from manufacturer, whichever occurs first, are limited to repair or replacement (including labor charges, of defective parts or assemblies). The labor warranty shall include standard straight time labor charges only and reasonable travel time, as determined by Alosa.

Additional Three Year Compressor Warranty

In addition to the two (2) year warranty stated above, Atosa warrants its sealed compressor to be free from defects in both material and workmanship under normal and proper use and maintenance service for a period of three (3) additional years from the date of original installation, but not to exceed five (5) years. Compressors that have been determined to be defective from Atosa within this extended period will be either repaired or replaced with a compressor or compressor parts of similar design and capacity according to Atosa's discretion. The three (3) year extended compressor warranty applies only to sealed parts of the compressor and does not apply to any other parts or components. This includes, the cabinet, paint finish, temperature control, refrigerant, metering device, motor starting equipment, fan assembly, and other electrical components, etc.

404A / 134a Compressor Warranty

The five-year compressor warranty detailed above will be void if the following procedure is not carefully adhered to:

1. This system contains R404A or R134a refrigerant and lubricant. The lubricant has rapid moisture absorbing qualities.
2. Drier replacement is very important and must be changed when a system is opened for servicing.
3. Micron level vacuums must be achieved to insure low moisture levels in the system.
4. Compressor must be obtained through Alosa, unless otherwise specified in writing, through Atosa's warranty department.

What is Not Covered by This Warranty

Atosa's sole obligation under this warranty is limited to either repair or replacement of parts, subject to the additional limitations below. This warranty neither assumes nor authorizes any person to assume obligations other than those expressly covered by this warranty.

Routine Maintenance requirements must be followed or warranty is Void

NO CONSEQUENTIAL DAMAGES: ATOSA IS NOT RESPONSIBLE FOR ECONOMIC LOSS; PROFIT LOSS; OR SPECIAL, INDIRECT, OR CONSEQUENTIAL DAMAGES, INCLUDING WITHOUT LIMITATION, LOSSES, OR DAMAGES ARISING FROM FOOD OR PRODUCT SPOilage, REGARDLESS OF WHETHER OR NOT THEY RESULT FROM REFRIGERATION FAILURE.

WARRANTY IS NOT TRANSFERABLE: This warranty is not assignable and applies only in favor of the original purchaser/user to whom delivered. ANY SUCH ASSIGNMENT OR TRANSFER SHALL VOID THE WARRANTIES HEREIN AND SHALL VOID ALL WARRANTIES, EXPRESS OR IMPLIED, INCLUDING ANY WARRANTY OF MERCHANTABILITY OR LABOR COVERAGE FOR COMPONENT FAILURE OR OTHER THE WARRANTY PACKET PROVIDED WITH THE UNIT.

ALTERATION, NEGLIGENCE, ABUSE, MISUSE, ACCIDENT, DAMAGE DURING TRANSIT OR INSTALLATION, FIRE, FOOD, OR ACTS OF GOD:

Atosa is not responsible for the repair or replacement of any parts that are determined to have been subjected after the date of manufacture to alteration, neglect, abuse, misuse, accident, damage during transit or installation, fire, flood, or act of God.

IMPROPER ELECTRICAL CONNECTIONS: Atosa IS NOT RESPONSIBLE FOR THE REPAIR OR REPLACEMENT OF FAILED OR DAMAGED COMPONENTS RESULTING FROM ELECTRICAL POWER FAILURE, THE USE OF EXTENSION CORDS, LOW VOLTAGE, OR VOLTAGE DROPS TO THE UNIT.

THE TWO (2) YEAR PARTS & LABOR WARRANTY AND THE ADDITIONAL THREE (3) YEAR COMPRESSOR WARRANTY ARE AS DESCRIBED ABOVE. THESE WARRANTIES ARE EXCLUSIVE AND IN LIEU OF ALL OTHER WARRANTIES, INCLUDING IMPLIED WARRANTY AND MERCHANTABILITY OR FITNESS FOR A PARTICULAR PURPOSE. THERE ARE NO WARRANTIES WHICH EXTEND BEYOND THE DESCRIPTION ON THE FACE HEREOF.

Outside U.S. and Canada: This warranty does not apply to areas outside the continent of the United States. Atosa is not responsible for any warranty claims made on products sold or used in such areas.

In some cases, a 25% restocking fee may be charged to a buyer for returned items.



ATOSACATERING EQUIPMENT INC.

WE ARE THE SPECICOOOLIST!

Toll Free:855-855-0399 Email:info@atosausa.com
 www.atosa.com | www.atosausa.com
 California,Colorado,Florida,Georgia, Illinois,Massachusetts,New Jersey,Ohio,Texas,
 Washington

Upright Refrigerator-Top Mount Series

Standard Features

- Top mount compressor units
- Exterior & interior stainless steel construction
- Dixell digital temperature control system
- Heavy duty Embraco compressor
- Self-closing and stay open door
- Efficient refrigeration system
- Round comer design
- Recessed door handle
- Standard safety door lock
- Magnetic door gaskets
- Pre-installed castors
- Pre-installed shelves
- 155lbs loading capacity per shelf

MBF8004



MBF8005



MBF8006



Specifications

Model	Doors	Cu.Ft	Shelves	Exterior Dimensions(W*D*H)	Packing Dimensions(W*D*H)	Castors	Gross Weight(LBS)	HP	Voltage	Amps	Refrigerant
MBF8004	1	22.6	3	28.74 X 33.27 X 82.89	30.4X34.7X85.8	4inch	264.88	16	115/60/1	4	R-134a
MBF8005	2	44.5	6	51.73X33.27X82.89	54.5X34.7X85.8	4inch	398.64	1/3	115/60/1	6.5	R-134a
MBF8006	3	69.2	9	77.8 X 33.27 X 82.89	80.7X34.7X85.8	4inch	557.04	1/3	115/60/1	7.6	R-134a

For best results of food preservation, we recommend setting your refrigerator between 33 'F - 38'F



2 YEARS WARRANIYON ALLPAITTSAND LABOR(US ONLY)
 5 YEARS WARRANTY ON ffIMPRESSOR(US ONLY)



1. Don't forget to leave the unit some room to breathe!
2. Please clean the condenser frequently to give the unit more fresh air.



Plan View

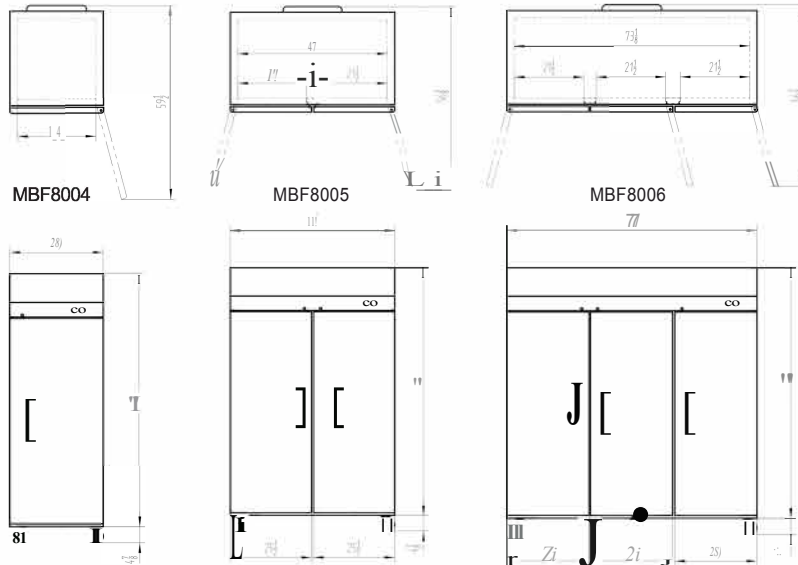

Side View

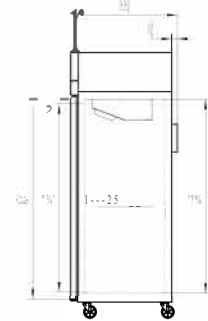

Terms and Conditions

2 YEAR WARRANTY

All claims for parts or labor must be made directly through Atosa. All claims must include: model number of the unit, the serial number, proof of purchase, date of installation, and all pertinent information supporting the alleged defect. In case of compressor replacement under warranty, either compressor or compressor tag must be returned to Alosa along with above listed information. Failure to comply with warranty policies will result in voiding claims.

Two Year Parts & Labor Warranty

Atosa warrants all new refrigerated components, such as the cabinet and all parts, to be free from defects in materials or workmanship. Atosa's obligation under this warranty is limited to a period of two (2) years from the date of original installation or 27 months after shipment date from Alosa, whichever occurs first. All parts covered under this warranty that are defective within two (2) years of original installation or twenty seven (27) months after shipment date from manufacturer, whichever occurs first, are limited to repair or replacement (including labor charges, of defective parts or assemblies). The labor warranty shall include standard straight time labor charges only and reasonable travel time, as determined by Alosa.

Additional Three Year Compressor Warranty

In addition to the two (2) year warranty stated above, Atosa warrants its sealed compressor to be free from defects in both material and workmanship under normal and proper use and maintenance service for a period of three (3) additional years from the date of original installation, but not to exceed five (5) years. Compressors that have been determined to be defective from Atosa within this extended period will be either repaired or replaced with a compressor or compressor parts of similar design and capacity according to Atosa's discretion. The three (3) year extended compressor warranty applies only to sealed parts of the compressor and does not apply to any other parts or components. This includes, the cabinet, paint finish, temperature control, refrigerant, metering device, motor starting equipment, fan assembly, and other electrical components, etc.

404A / 134a Compressor Warranty

The five-year compressor warranty detailed above will be void if the following procedure is not carefully adhered to:

1. This system contains R404A or R134a refrigerant and lubricant. The lubricant has rapid moisture absorbing qualities.
2. Drier replacement is very important and must be changed when a system is opened for servicing.
3. Micron level vacuums must be achieved to insure low moisture levels in the system.
4. Compressor must be obtained through Alosa, unless otherwise specified in writing, through Atosa's warranty department.

What is Not Covered by This Warranty

Atosa's sole obligation under this warranty is limited to either repair or replacement of parts, subject to the additional limitations below. This warranty neither assumes nor authorizes any person to assume obligations other than those expressly covered by this warranty.

Routine Maintenance requirements must be followed or warranty is Void

NO CONSEQUENTIAL DAMAGES: ATOSA IS NOT RESPONSIBLE FOR ECONOMIC LOSS; PROFIT LOSS; OR SPECIAL, INDIRECT, OR CONSEQUENTIAL DAMAGES, INCLUDING WITHOUT LIMITATION, LOSSES, OR DAMAGES ARISING FROM FOOD OR PRODUCT SPOilage, REGARDLESS OF WHETHER OR NOT THEY RESULT FROM REFRIGERATION FAILURE.

WARRANTY IS NOT TRANSFERABLE: This warranty is not assignable and applies only in favor of the original purchaser/user to whom delivered. ANY SUCH ASSIGNMENT OR TRANSFER SHALL VOID THE WARRANTIES HEREIN AND SHALL VOID ALL WARRANTIES, EXPRESS OR IMPLIED, INCLUDING ANY WARRANTY OF MERCHANTABILITY OR LABOR COVERAGE FOR COMPONENT FAILURE OR OTHER THE WARRANTY PACKET PROVIDED WITH THE UNIT.

ALTERATION, NEGLIGENCE, ABUSE, MISUSE, ACCIDENT, DAMAGE DURING TRANSIT OR INSTALLATION, FIRE, FOOD, OR ACTS OF GOD:

Atosa is not responsible for the repair or replacement of any parts that are determined to have been subjected after the date of manufacture to alteration, neglect, abuse, misuse, accident, damage during transit or installation, fire, flood, or act of God.

IMPROPER ELECTRICAL CONNECTIONS: Atosa IS NOT RESPONSIBLE FOR THE REPAIR OR REPLACEMENT OF FAILED OR DAMAGED COMPONENTS RESULTING FROM ELECTRICAL POWER FAILURE, THE USE OF EXTENSION CORDS, LOW VOLTAGE, OR VOLTAGE DROPS TO THE UNIT.

THE TWO (2) YEAR PARTS & LABOR WARRANTY AND THE ADDITIONAL THREE (3) YEAR COMPRESSOR WARRANTY ARE AS DESCRIBED ABOVE. THESE WARRANTIES ARE EXCLUSIVE AND IN LIEU OF ALL OTHER WARRANTIES, INCLUDING IMPLIED WARRANTY AND MERCHANTABILITY OR FITNESS FOR A PARTICULAR PURPOSE. THERE ARE NO WARRANTIES WHICH EXTEND BEYOND THE DESCRIPTION ON THE FACE HEREOF.

Outside U.S. and Canada: This warranty does not apply to areas outside the continent of the United States. Atosa is not responsible for any warranty claims made on products sold or used in such areas.

In some cases, a 25% restocking fee may be charged to a buyer for returned items.



ATOSACATERING EQUIPMENT INC.

WE ARE THE SPECICOOOLIST!

Toll Free:855-855-0399 Email:info@atosausa.com
 www.atosa.com | www.atosausa.com
 California,Colorado,Florida,Georgia, Illinois,Massachusetts,New Jersey,Ohio,Texas,
 Washington

Upright Freezer-Bottom Mount Series

Standard Features

- Bottom mount compressor units
- Exterior & interior stainless steel construction
- Dixell digital temperature control system
- Heavy duty Embrace compressor
- Self-closing and stay open door
- Efficient refrigeration system
- Round comer design
- Recessed door handle
- Standard safety door lock
- Magnetic door gaskets
- Pre-installed castors
- Pre-installed shelves
- 155lbs loading capacity per shelf

MBF8501



MBF8503



MBF8504



Specifications

Model	Doors	Cu.Ft	Shelves	Exterior Dimensions(W*D*H)	Packing Dimensions(W*D*H)	Castors	Gross Weight(LBS)	HP	Voltage	Amps	Refrigerant
MBF8501	1	21	3	26.97 X 31.5 X 83.16	28.8 X 33.1 X 85.8	4inch	229.2	1/2	115/60/1	7.5	R-404a
MBF8503	2	46	6	54.41 X 31.5 X 83.16	56.2 X 33.1 X 85.8	4inch	456.72	3/4	115/60/1	12	R-404a
MBF8504	3	71	9	81.85 X 31.5 X 83.16	83.7 X 33.1 X 85.8	4inch	637.56	1	115/208-230/60/1	5.5	R-404a

For best results of food preservation, we recommend setting your freezer between OF - 8°F



2 YEARS WARRANIYON ALLPAITTSAND LABOR(US ONLY)
 5 YEARS WARRANTY ON ffIMPRESSOR(US ONLY)



1. Don't forget to leave the unit some room to breathe!
2. Please clean the condenser frequently to give the unit more fresh air.
3. Energy Star only for MBF8503 and MBF8504.



Plan View

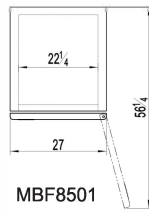

MBF8501

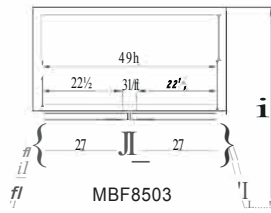

MBF8503

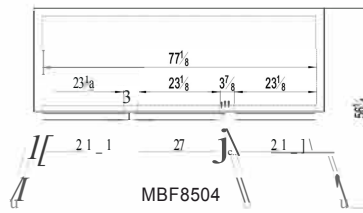

MBF8504

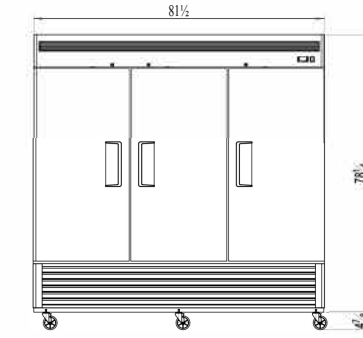
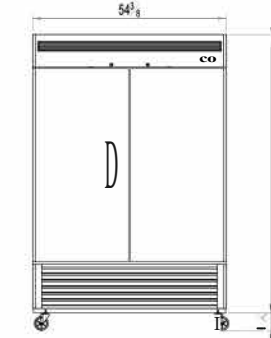

Side View

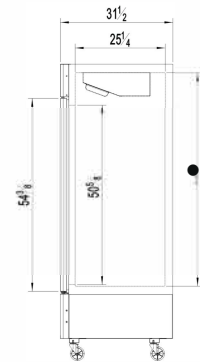

Terms and Conditions

2 YEAR WARRANTY

All claims for parts or labor must be made directly through Atosa. All claims must include: model number of the unit, the serial number, proof of purchase, date of installation, and all pertinent information supporting the alleged defect. In case of compressor replacement under warranty, either compressor or compressor tag must be returned to Alosa along with above listed information. **Failure to comply with warranty policies will result in voiding claims.**

Two Year Parts & Labor Warranty

Atosa warrants all new refrigerated components, such as the cabinet and all parts, to be free from defects in materials or workmanship. Atosa's obligation under this warranty is limited to a period of two (2) years from the date of original installation or 27 months after shipment date from Alosa, whichever occurs first. All parts covered under this warranty that are defective within two (2) years of original installation or twenty seven (27) months after shipment date from manufacturer, whichever occurs first, are limited to repair or replacement (including labor charges, of defective parts or assemblies). The labor warranty shall include standard straight time labor charges only and reasonable travel time, as determined by Alosa.

Additional Three Year Compressor Warranty

In addition to the two (2) year warranty stated above, Atosa warrants its sealed compressor to be free from defects in both material and workmanship under normal and proper use and maintenance service for a period of three (3) additional years from the date of original installation, but not to exceed five (5) years. Compressors that have been determined to be defective from Atosa within this extended period will be either repaired or replaced with a compressor or compressor parts of similar design and capacity according to Atosa's discretion. The three (3) year extended compressor warranty applies only to sealed parts of the compressor and does not apply to any other parts or components. This includes, the cabinet, paint finish, temperature control, refrigerant, metering device, motor starting equipment, fan assembly, and other electrical components, etc.

404A / 134a Compressor Warranty

The five-year compressor warranty detailed above will be void if the following procedure is not carefully adhered to:

1. This system contains R404A or R134a refrigerant and lubricant. The lubricant has rapid moisture absorbing qualities.
2. Drier replacement is very important and must be changed when a system is opened for servicing.
3. Micron level vacuums must be achieved to insure low moisture levels in the system.
4. Compressor must be obtained through Alosa, unless otherwise specified in writing, through Atosa's warranty department.

What is Not Covered by This Warranty

Atosa's sole obligation under this warranty is limited to either repair or replacement of parts, subject to the additional limitations below. This warranty neither assumes nor authorizes any person to assume obligations other than those expressly covered by this warranty.

Routine Maintenance requirements must be followed or warranty is Void

NO CONSEQUENTIAL DAMAGES: ATOSA IS NOT RESPONSIBLE FOR ECONOMIC LOSS; PROFIT LOSS; OR SPECIAL, INDIRECT, OR CONSEQUENTIAL DAMAGES, INCLUDING WITHOUT LIMITATION, LOSSES, OR DAMAGES ARISING FROM FOOD OR PRODUCT SPOilage, REGARDLESS OF WHETHER OR NOT THEY RESULT FROM REFRIGERATION FAILURE.

WARRANTY IS NOT TRANSFERABLE: This warranty is not assignable and applies only in favor of the original purchaser/user to whom delivered. ANY SUCH ASSIGNMENT OR TRANSFER SHALL VOID THE WARRANTIES HEREIN AND SHALL VOID ALL WARRANTIES, EXPRESS OR IMPLIED, INCLUDING ANY WARRANTY OF MERCHANTABILITY OR LABOR COVERAGE FOR COMPONENT FAILURE OR OTHER THE WARRANTY PACKET PROVIDED WITH THE UNIT.

ALTERATION, NEGLIGENCE, ABUSE, MISUSE, ACCIDENT, DAMAGE DURING TRANSIT OR INSTALLATION, FIRE, FOOD, OR ACTS OF GOD:

Atosa is not responsible for the repair or replacement of any parts that are determined to have been subjected after the date of manufacture to alteration, neglect, abuse, misuse, accident, damage during transit or installation, fire, flood, or act of God.

IMPROPER ELECTRICAL CONNECTIONS: Atosa IS NOT RESPONSIBLE FOR THE REPAIR OR REPLACEMENT OF FAILED OR DAMAGED COMPONENTS RESULTING FROM ELECTRICAL POWER FAILURE, THE USE OF EXTENSION CORDS, LOW VOLTAGE, OR VOLTAGE DROPS TO THE UNIT.

THE TWO (2) YEAR PARTS & LABOR WARRANTY AND THE ADDITIONAL THREE (3) YEAR COMPRESSOR WARRANTY ARE AS DESCRIBED ABOVE. THESE WARRANTIES ARE EXCLUSIVE AND IN LIEU OF ALL OTHER WARRANTIES, INCLUDING IMPLIED WARRANTY AND MERCHANTABILITY OR FITNESS FOR A PARTICULAR PURPOSE. THERE ARE NO WARRANTIES WHICH EXTEND BEYOND THE DESCRIPTION ON THE FACE HEREOF.

Outside U.S. and Canada: This warranty does not apply to areas outside the continent of the United States. Atosa is not responsible for any warranty claims made on products sold or used in such areas.

In some cases, a 25% restocking fee may be charged to a buyer for returned items.



ATOSACATERING EQUIPMENT INC.

WE ARE THE SPECICOOOLIST!

Toll Free:855-855-0399 Email:info@atosausa.com
 www.atosa.com | www.atosausa.com
 California,Colorado,Florida,Georgia, Illinois,Massachusetts,New Jersey,Ohio,Texas,
 Washington

Upright Refrigerator- Bottom Mount Series

Standard Features

- Bottom mount compressor units
- Exterior & interior stainless steel construction
- Dixell digital temperature control system
- Heavy duty Embrace compressor
- Self-closing and stay open door
- Efficient refrigeration system
- Round corner design
- Recessed door handle
- Standard safety door lock
- Magnetic door gaskets
- Pre-installed castors
- Pre-installed shelves
- 155lbs loading capacity per shelf



MBF8505



MBF8507



MBF8508



Specifications

Model	Doors	Cu.Ft	Shelves	Exterior Dimensions(W*D*H)	Packing Dimensions(W*D*H)	Castors	Gross Weight(LBS)	HP	Voltage	Amps	Refrigerant
MBF8505	1	21	3	26.97 X 31.5 X 83.16	28.8 X 33.1 X 85.8	4inch	228.24	1/6	115/60/1	4	R-134a
MBF8507	2	46	6	54.41 X 31.5 X 83.16	56.2 X 33.1 X 85.8	4inch	444.4	1/3	115/60/1	6.5	R-134a
MBF8508	3	71	9	81.85 X 31.5 X 83.16	83.7 X 33.1 X 85.8	4inch	637.56	1/3	115/60/1	7.6	R-134a

For best results of food presevation, we recommend setting your refrigerator between 33 'F - 38"F



2 YEARS WARRANIYON ALLPAITTSAND LABOR(US ONLY)
 5 YEARS WARRANTY ON ffIMPRESSOR(US ONLY)



1. Don't forget to leave the unit some room to breathe!
2. Please clean the condenser frequently to give the unit more fresh air.



Plan View

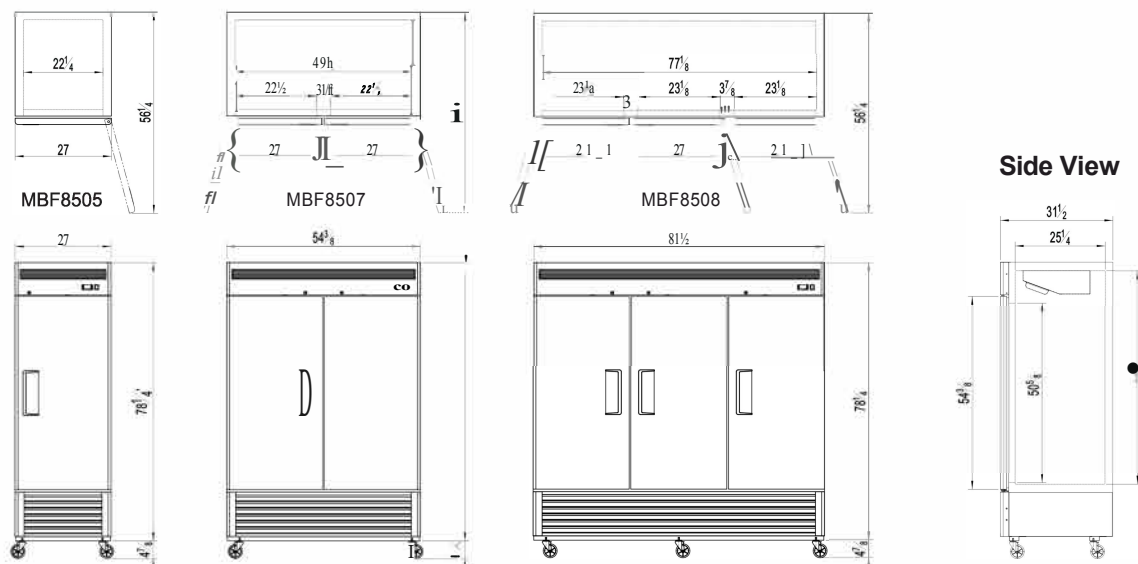

Terms and Conditions

2 YEAR WARRANTY

All claims for parts or labor must be made directly through Atosa. All claims must include: model number of the unit, the serial number, proof of purchase, date of installation, and all pertinent information supporting the alleged defect. In case of compressor replacement under warranty, either compressor or compressor tag must be returned to Alosa along with above listed information. **Failure to comply with warranty policies will result in voiding claims.**

Two Year Parts & Labor Warranty

Atosa warrants all new refrigerated components, such as the cabinet and all parts, to be free from defects in materials or workmanship. Atosa's obligation under this warranty is limited to a period of two (2) years from the date of original installation or 27 months after shipment date from Alosa, whichever occurs first. All parts covered under this warranty that are defective within two (2) years of original installation or twenty seven (27) months after shipment date from manufacturer, whichever occurs first, are limited to repair or replacement (including labor charges, of defective parts or assemblies). The labor warranty shall include standard straight time labor charges only and reasonable travel time, as determined by Alosa.

Additional Three Year Compressor Warranty

In addition to the two (2) year warranty stated above, Atosa warrants its sealed compressor to be free from defects in both material and workmanship under normal and proper use and maintenance service for a period of three (3) additional years from the date of original installation, but not to exceed five (5) years. Compressors that have been determined to be defective from Atosa within this extended period will be either repaired or replaced with a compressor or compressor parts of similar design and capacity according to Atosa's discretion. The three (3) year extended compressor warranty applies only to sealed parts of the compressor and does not apply to any other parts or components. This includes, the cabinet, paint finish, temperature control, refrigerant, metering device, motor starting equipment, fan assembly, and other electrical components, etc.

404A / 134a Compressor Warranty

The five-year compressor warranty detailed above will be void if the following procedure is not carefully adhered to:

1. This system contains R404A or R134a refrigerant and lubricant. The lubricant has rapid moisture absorbing qualities.
2. Drier replacement is very important and must be changed when a system is opened for servicing.
3. Micron level vacuums must be achieved to insure low moisture levels in the system.
4. Compressor must be obtained through Alosa, unless otherwise specified in writing, through Atosa's warranty department.

What is Not Covered by This Warranty

Atosa's sole obligation under this warranty is limited to either repair or replacement of parts, subject to the additional limitations below. This warranty neither assumes nor authorizes any person to assume obligations other than those expressly covered by this warranty.

Routine Maintenance requirements must be followed or warranty is Void

NO CONSEQUENTIAL DAMAGES: ATOSA IS NOT RESPONSIBLE FOR ECONOMIC LOSS; PROFIT LOSS; OR SPECIAL, INDIRECT, OR CONSEQUENTIAL DAMAGES, INCLUDING WITHOUT LIMITATION, LOSSES, OR DAMAGES ARISING FROM FOOD OR PRODUCT SPOilage, REGARDLESS OF WHETHER OR NOT THEY RESULT FROM REFRIGERATION FAILURE.

WARRANTY IS NOT TRANSFERABLE: This warranty is not assignable and applies only in favor of the original purchaser/user to whom delivered. ANY SUCH ASSIGNMENT OR TRANSFER SHALL VOID THE WARRANTIES HEREIN AND SHALL VOID ALL WARRANTIES, EXPRESS OR IMPLIED, INCLUDING ANY WARRANTY OF MERCHANTABILITY OR LABOR COVERAGE FOR COMPONENT FAILURE OR OTHER THE WARRANTY PACKET PROVIDED WITH THE UNIT.

ALTERATION, NEGLIGENCE, ABUSE, MISUSE, ACCIDENT, DAMAGE DURING TRANSIT OR INSTALLATION, FIRE, FOOD, OR ACTS OF GOD:

Atosa is not responsible for the repair or replacement of any parts that are determined to have been subjected after the date of manufacture to alteration, neglect, abuse, misuse, accident, damage during transit or installation, fire, flood, or act of God.

IMPROPER ELECTRICAL CONNECTIONS: Atosa IS NOT RESPONSIBLE FOR THE REPAIR OR REPLACEMENT OF FAILED OR DAMAGED COMPONENTS RESULTING FROM ELECTRICAL POWER FAILURE, THE USE OF EXTENSION CORDS, LOW VOLTAGE, OR VOLTAGE DROPS TO THE UNIT.

THE TWO (2) YEAR PARTS & LABOR WARRANTY AND THE ADDITIONAL THREE (3) YEAR COMPRESSOR WARRANTY ARE AS DESCRIBED ABOVE. THESE WARRANTIES ARE EXCLUSIVE AND IN LIEU OF ALL OTHER WARRANTIES, INCLUDING IMPLIED WARRANTY AND MERCHANTABILITY OR FITNESS FOR A PARTICULAR PURPOSE. THERE ARE NO WARRANTIES WHICH EXTEND BEYOND THE DESCRIPTION ON THE FACE HEREOF.

Outside U.S. and Canada: This warranty does not apply to areas outside the continent of the United States. Atosa is not responsible for any warranty claims made on products sold or used in such areas.

In some cases, a 25% restocking fee may be charged to a buyer for returned items.



ATOSACATERING EQUIPMENT INC.

WE ARE THE SPECICOOOLIST!

Toll Free:855-855-0399 Email:info@atosausa.com
 www.atosa.com |www.atosausa.com
 California,Colorado,Florida,Georgia, Illinois,Massachusetts,New Jersey,Ohio,Texas,
 Washington

Glass Door Merchandiser-Freezer Series

Standard Features

- Bottom mount compressor units
- Led lighting interior display system
- Dixell digital temperature control system
- Heavy duty Embrace compressor
- Self-closing and stay open door
- Efficient refrigeration system
- Round comer design
- Recessed door handle
- Standard safety door lock
- Magnetic door gaskets
- Pre-installed castors
- Pre-installed shelves
- 155lbs loading capacity per shelf

MCF8701



MCF8703



Specifications

Model	Doors	Cu.Ft	Shelves	Exterior Dimensions(W*D*H)	Packing Dimensions(W*D*H)	Castors	Gross Weight(LBS)	HP	Voltage	Amps	Refrigerant
MCF8701	1	21	4	26.97 X 31.5 X 83.16	28.8 X 33.1 X 84.2	4inch	345.4	1/2	115/60/1	7.5	R-404a
MCF8703	2	47.1	8	54.41 X31.5X83.16	56.2X33.1 X84.2	4inch	553.08	3/4	115/60/1	12	R-404a

For best results of food presevation, we recommend setting your freezer between 0°F - 8°F



2 YEARS WARRANIYON ALLPAITTSAND LABOR(US ONLY)
 5 YEARS WARRANTY ON ffIMPRESSOR(US ONLY)



1. Don't forget to leave the unit some room to breathe!
2. Please clean the condenser frequently to give the unit more fresh air.



Plan View

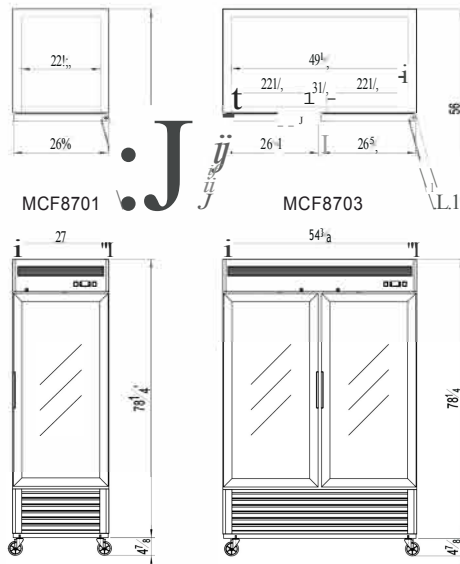

Side View

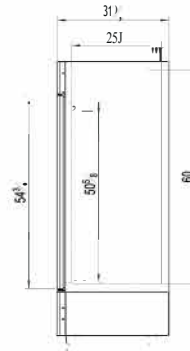

Terms and Conditions

2 YEAR WARRANTY

All claims for parts or labor must be made directly through Atosa. All claims must include: model number of the unit, the serial number, proof of purchase, date of installation, and all pertinent information supporting the alleged defect. In case of compressor replacement under warranty, either compressor or compressor tag must be returned to Alosa along with above listed information. **Failure to comply with warranty policies will result in voiding claims.**

Two Year Parts & Labor Warranty

Atosa warrants all new refrigerated components, such as the cabinet and all parts, to be free from defects in materials or workmanship. Atosa's obligation under this warranty is limited to a period of two (2) years from the date of original installation or 27 months after shipment date from Alosa, whichever occurs first. All parts covered under this warranty that are defective within two (2) years of original installation or twenty seven (27) months after shipment date from manufacturer, whichever occurs first, are limited to repair or replacement (including labor charges, of defective parts or assemblies). The labor warranty shall include standard straight time labor charges only and reasonable travel time, as determined by Alosa.

Additional Three Year Compressor Warranty

In addition to the two (2) year warranty stated above, Atosa warrants its sealed compressor to be free from defects in both material and workmanship under normal and proper use and maintenance service for a period of three (3) additional years from the date of original installation, but not to exceed five (5) years. Compressors that have been determined to be defective from Atosa within this extended period will be either repaired or replaced with a compressor or compressor parts of similar design and capacity according to Atosa's discretion. The three (3) year extended compressor warranty applies only to sealed parts of the compressor and does not apply to any other parts or components. This includes, the cabinet, paint finish, temperature control, refrigerant, metering device, motor starting equipment, fan assembly, and other electrical components, etc.

404A / 134a Compressor Warranty

The five-year compressor warranty detailed above will be void if the following procedure is not carefully adhered to:

1. This system contains R404A or R134a refrigerant and lubricant. The lubricant has rapid moisture absorbing qualities.
2. Drier replacement is very important and must be changed when a system is opened for servicing.
3. Micron level vacuums must be achieved to insure low moisture levels in the system.
4. Compressor must be obtained through Alosa, unless otherwise specified in writing, through Atosa's warranty department.

What is Not Covered by This Warranty

Atosa's sole obligation under this warranty is limited to either repair or replacement of parts, subject to the additional limitations below. This warranty neither assumes nor authorizes any person to assume obligations other than those expressly covered by this warranty.

Routine Maintenance requirements must be followed or warranty is Void

NO CONSEQUENTIAL DAMAGES: ATOSA IS NOT RESPONSIBLE FOR ECONOMIC LOSS; PROFIT LOSS; OR SPECIAL, INDIRECT, OR CONSEQUENTIAL DAMAGES, INCLUDING WITHOUT LIMITATION, LOSSES, OR DAMAGES ARISING FROM FOOD OR PRODUCT SPOilage, REGARDLESS OF WHETHER OR NOT THEY RESULT FROM REFRIGERATION FAILURE.

WARRANTY IS NOT TRANSFERABLE: This warranty is not assignable and applies only in favor of the original purchaser/user to whom delivered. ANY SUCH ASSIGNMENT OR TRANSFER SHALL VOID THE WARRANTIES HEREIN AND SHALL VOID ALL WARRANTIES, EXPRESS OR IMPLIED, INCLUDING ANY WARRANTY OF MERCHANTABILITY OR LABOR COVERAGE FOR COMPONENT FAILURE OR OTHER THE WARRANTY PACKET PROVIDED WITH THE UNIT.

ALTERATION, NEGLIGENCE, ABUSE, MISUSE, ACCIDENT, DAMAGE DURING TRANSIT OR INSTALLATION, FIRE, FOOD, OR ACTS OF GOD:

Atosa is not responsible for the repair or replacement of any parts that are determined to have been subjected after the date of manufacture to alteration, neglect, abuse, misuse, accident, damage during transit or installation, fire, flood, or act of God.

IMPROPER ELECTRICAL CONNECTIONS: Atosa IS NOT RESPONSIBLE FOR THE REPAIR OR REPLACEMENT OF FAILED OR DAMAGED COMPONENTS RESULTING FROM ELECTRICAL POWER FAILURE, THE USE OF EXTENSION CORDS, LOW VOLTAGE, OR VOLTAGE DROPS TO THE UNIT.

THE TWO (2) YEAR PARTS & LABOR WARRANTY AND THE ADDITIONAL THREE (3) YEAR COMPRESSOR WARRANTY ARE AS DESCRIBED ABOVE. THESE WARRANTIES ARE EXCLUSIVE AND IN LIEU OF ALL OTHER WARRANTIES, INCLUDING IMPLIED WARRANTY AND MERCHANTABILITY OR FITNESS FOR A PARTICULAR PURPOSE. THERE ARE NO WARRANTIES WHICH EXTEND BEYOND THE DESCRIPTION ON THE FACE HEREOF.

Outside U.S. and Canada: This warranty does not apply to areas outside the continent of the United States. Atosa is not responsible for any warranty claims made on products sold or used in such areas.

In some cases, a 25% restocking fee may be charged to a buyer for returned items.



ATOSACATERING EQUIPMENT INC.

WE ARE THE SPECICOOOLIST!

Toll Free:855-855-0399 Email:info@atosausa.com
 www.atosa.com | www.atosausa.com
 California,Colorado,Florida,Georgia, Illinois,Massachusetts,New Jersey,Ohio,Texas,
 Washington

Glass Door Merchandiser-Refrigerator Series

Standard Features

- Bottom mount compressor units
- Led lighting interior display system
- Dixell digital temperature control system
- Heavy duty Embrace compressor
- Self-closing and stay open door
- Efficient refrigeration system
- Round comer design
- Recessed door handle
- Standard safety door lock
- Magnetic door gaskets
- Pre-installed castors
- Pre-installed shelves
- 155lbs loading capacity per shelf

MCF8705



MCF8707



MCF8709



Specifications

Model	Doors	Cu.Ft	Shelves	Exterior Dimensions(W*D*H)	Packing Dimensions(W*D*H)	Castors	Gross Weight(LBS)	HP	Voltage	Amps	Refrigerant
MCF8705	1	22	4	26.97 X 31.5 X 83.16	28.8 X 33.1 X 84.2	4inch	314.16	1/6	115/60/1	3.2	R-134a
MCF8707	2	47.1	8	54.41 X 31.5 X 83.16	56.2 X 33.1 X 84.2	4inch	508.64	1/3	115/60/1	4.3	R-134a
MCF8709	2	45	8	54.41 X 29.92 X 81.19	56.2 X 31.5 X 84.2	2inch	499.4	1/3	115/60/1	4.3	R-404a

For best results of food presevation, we recommend setting your refrigerator between 33 'F - 38"F



2 YEARS WARRANIYON ALLPAITTSAND LABOR(US ONLY)
 5 YEARS WARRANTY ON ffIMPRESSOR(US ONLY)



1. Don't forget to leave the unit some room to breathe!
2. Please clean the condenser frequently to give the unit more fresh air.
3. Energy Star only for MCF8705 and MCF8707.

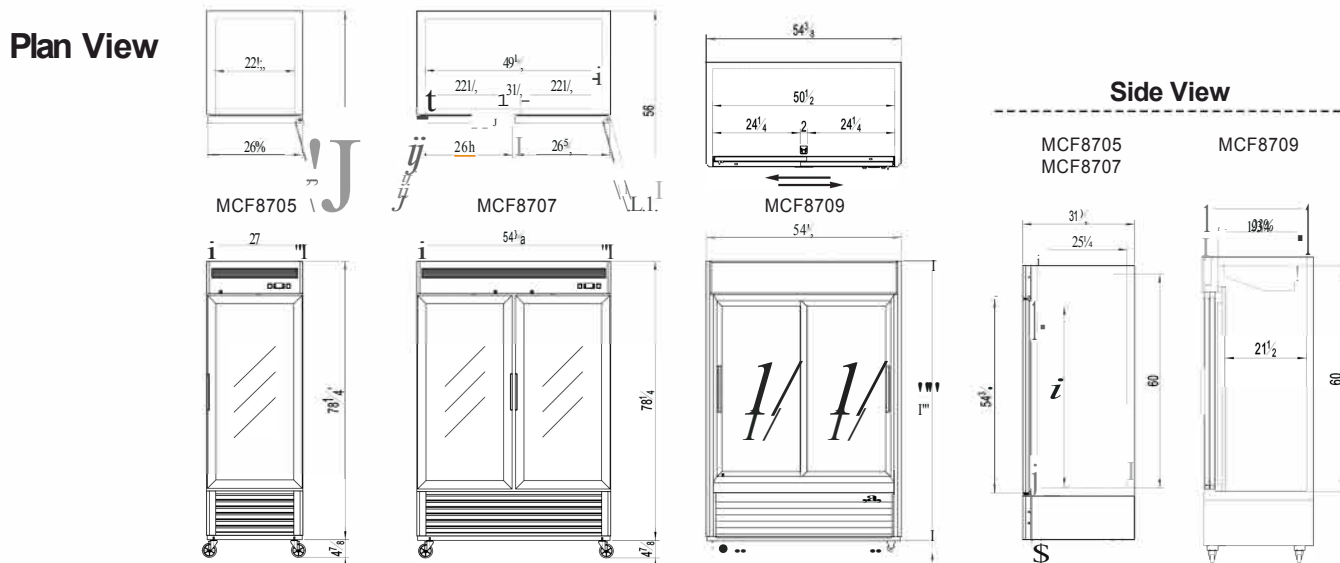

Terms and Conditions

2 YEAR WARRANTY

All claims for parts or labor must be made directly through Atosa. All claims must include: model number of the unit, the serial number, proof of purchase, date of installation, and all pertinent information supporting the alleged defect. In case of compressor replacement under warranty, either compressor or compressor tag must be returned to Alosa along with above listed information. **Failure to comply with warranty policies will result in voiding claims.**

Two Year Parts & Labor Warranty

Atosa warrants all new refrigerated components, such as the cabinet and all parts, to be free from defects in materials or workmanship. Atosa's obligation under this warranty is limited to a period of two (2) years from the date of original installation or 27 months after shipment date from Alosa, whichever occurs first. All parts covered under this warranty that are defective within two (2) years of original installation or twenty seven (27) months after shipment date from manufacturer, whichever occurs first, are limited to repair or replacement (including labor charges, of defective parts or assemblies). The labor warranty shall include standard straight time labor charges only and reasonable travel time, as determined by Alosa.

Additional Three Year Compressor Warranty

In addition to the two (2) year warranty stated above, Atosa warrants its sealed compressor to be free from defects in both material and workmanship under normal and proper use and maintenance service for a period of three (3) additional years from the date of original installation, but not to exceed five (5) years. Compressors that have been determined to be defective from Atosa within this extended period will be either repaired or replaced with a compressor or compressor parts of similar design and capacity according to Atosa's discretion. The three (3) year extended compressor warranty applies only to sealed parts of the compressor and does not apply to any other parts or components. This includes, the cabinet, paint finish, temperature control, refrigerant, metering device, motor starting equipment, fan assembly, and other electrical components, etc.

404A / 134a Compressor Warranty

The five-year compressor warranty detailed above will be void if the following procedure is not carefully adhered to:

1. This system contains R404A or R134a refrigerant and lubricant. The lubricant has rapid moisture absorbing qualities.
2. Drier replacement is very important and must be changed when a system is opened for servicing.
3. Micron level vacuums must be achieved to insure low moisture levels in the system.
4. Compressor must be obtained through Alosa, unless otherwise specified in writing, through Atosa's warranty department.

What is Not Covered by This Warranty

Atosa's sole obligation under this warranty is limited to either repair or replacement of parts, subject to the additional limitations below. This warranty neither assumes nor authorizes any person to assume obligations other than those expressly covered by this warranty.

Routine Maintenance requirements must be followed or warranty is Void

NO CONSEQUENTIAL DAMAGES: ATOSA IS NOT RESPONSIBLE FOR ECONOMIC LOSS; PROFIT LOSS; OR SPECIAL, INDIRECT, OR CONSEQUENTIAL DAMAGES, INCLUDING WITHOUT LIMITATION, LOSSES, OR DAMAGES ARISING FROM FOOD OR PRODUCT SPOilage, REGARDLESS OF WHETHER OR NOT THEY RESULT FROM REFRIGERATION FAILURE.

WARRANTY IS NOT TRANSFERABLE: This warranty is not assignable and applies only in favor of the original purchaser/user to whom delivered. ANY SUCH ASSIGNMENT OR TRANSFER SHALL VOID THE WARRANTIES HEREIN AND SHALL VOID ALL WARRANTIES, EXPRESS OR IMPLIED, INCLUDING ANY WARRANTY OF MERCHANTABILITY OR LABOR COVERAGE FOR COMPONENT FAILURE OR OTHER THE WARRANTY PACKET PROVIDED WITH THE UNIT.

ALTERATION, NEGLIGENCE, ABUSE, MISUSE, ACCIDENT, DAMAGE DURING TRANSIT OR INSTALLATION, FIRE, FOOD, OR ACTS OF GOD:

Atosa is not responsible for the repair or replacement of any parts that are determined to have been subjected after the date of manufacture to alteration, neglect, abuse, misuse, accident, damage during transit or installation, fire, flood, or act of God.

IMPROPER ELECTRICAL CONNECTIONS: Atosa IS NOT RESPONSIBLE FOR THE REPAIR OR REPLACEMENT OF FAILED OR DAMAGED COMPONENTS RESULTING FROM ELECTRICAL POWER FAILURE, THE USE OF EXTENSION CORDS, LOW VOLTAGE, OR VOLTAGE DROPS TO THE UNIT.

THE TWO (2) YEAR PARTS & LABOR WARRANTY AND THE ADDITIONAL THREE (3) YEAR COMPRESSOR WARRANTY ARE AS DESCRIBED ABOVE. THESE WARRANTIES ARE EXCLUSIVE AND IN LIEU OF ALL OTHER WARRANTIES, INCLUDING IMPLIED WARRANTY AND MERCHANTABILITY OR FITNESS FOR A PARTICULAR PURPOSE. THERE ARE NO WARRANTIES WHICH EXTEND BEYOND THE DESCRIPTION ON THE FACE HEREOF.

Outside U.S. and Canada: This warranty does not apply to areas outside the continent of the United States. Atosa is not responsible for any warranty claims made on products sold or used in such areas.

In some cases, a 25% restocking fee may be charged to a buyer for returned items.



ATOSA CATERING EQUIPMENT INC.

WE ARE THE SPECICOOOLIST !

Toll Free:855-855-0399 Email:info@atosausa.com
www.atosa.com | www.atosausa.com

California, Colorado, Florida, Georgia, Illinois, Massachusetts, New Jersey, Ohio, Texas, Washington

Undercounter Refrigerator Series

Standard Features

- Exterior & interior stainless steel construction
- Heavy duty Embraco compressor
- Self-closing and stay open door
- Efficient refrigeration system
- Round corner design
- Recessed door handle
- Standard safety door lock
- Magnetic door gaskets
- Pre-installed castors
- Pre-installed shelves
- 155lbs loading capacity per shelf



MGF8401



MGF8402



MGF8403



MGF8404



Specifications

Model	Doors	Cu.Ft	Shelves	Exterior Dimensions(WD*H)	Packing Dimensions(WD*H)	Castors	Gross Weight(LBS)	HP	Voltage	Amps	Refrigerant
MGF8401	1	6.5	1	27.48X30X37.16	30.3 X 33.6 X 38.2	5inch	169.84	1/6	115/60/1	3.2	R-134a
MGF8402	2	12	2	48.23X30X37.16	51.2 X 33.6 X 38.2	5inch	230.56	1/6	115/60/1	4.2	R-134a
MGF8403	2	17.9	2	60.24X30X37.16	63.0 X 33.6 X 38.2	5inch	275	1/4	115/60/1	4.2	R-134a
MGF8404	3	32.8	3	72.68X30X37.16	75.5 X 33.6 X 38.2	5inch	314.6	1/4	115/60/1	4.2	R-134a

For best results of food preservation, we recommend setting your refrigerator between 33 'F - 38''F



2 YEARS WARRANTY ON ALL PARTS AND LABOR (US ONLY)
5 YEARS WARRANTY ON COMPRESSOR (US ONLY)



1. Don't forget to leave the unit some room to breathe!
2. Please clean the condenser frequently to give the unit more fresh air.



Plan View

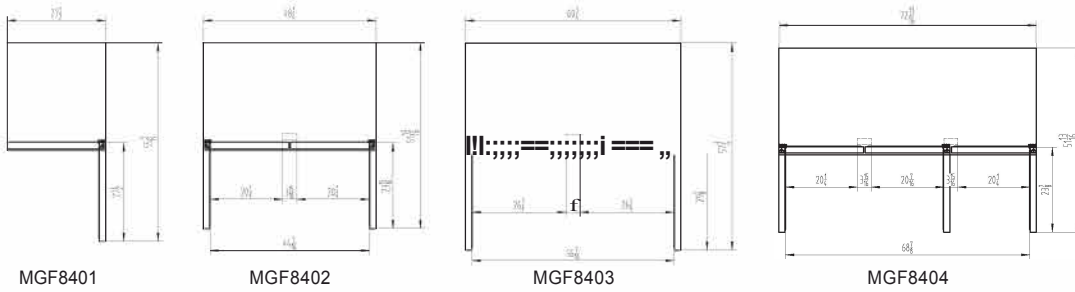

Side View

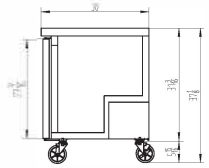

CJ cr:J

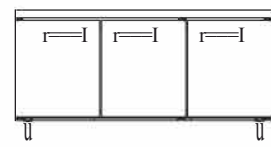
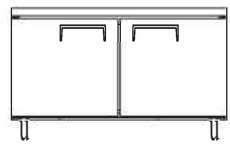

Tenns and Conditions

2 YEAR WARRANTY

All claims for parts or labor must be made directly through Atosa. All claims must include: model number of the unit, the serial number, proof of purchase, date of installation, and all pertinent information supporting the alleged defect. In case of compressor replacement under warranty, either compressor or compressor tag must be returned to Atosa along with above listed information. **Failure to comply with warranty policies will result in voiding claims.**

Two Year Parts & Labor Warranty

Atosa warrants all new refrigerated components, such as the cabinet and all parts, to be free from defects in materials or workmanship. Atosa's obligation under this warranty is limited to a period of two (2) years from the date of original installation or 27 months after shipment date from Atosa, whichever occurs first. All parts covered under this warranty that are defective within two (2) years of original installation or twenty seven (27) months after shipment date from manufacturer, whichever occurs first, are limited to repair or replacement (including labor charges, of defective parts or assemblies). The labor warranty shall include standard straight time labor charges only and reasonable travel time, as determined by Atosa.

Additional Three Year Compressor Warranty

In addition to the two (2) year warranty stated above, Atosa warrants its sealed compressor to be free from defects in both material and workmanship under normal and proper use and maintenance service for a period of three (3) additional years from the date of original installation, but not to exceed five (5) years. Compressors that have been determined to be defective from Atosa within this extended period will be either repaired or replaced with a compressor or compressor parts of similar design and capacity according to Atosa's discretion. The three (3) year extended compressor warranty applies only to sealed parts of the compressor and does not apply to any other parts or components. This includes, the cabinet, paint finish, temperature control, refrigerant, metering device, motor starting equipment, fan assembly, and other electrical components, etc.

404A / 134a Compressor Warranty

The five-year compressor warranty detailed above will be void if the following procedure is not carefully adhered to:

1. This system contains R404A or RI 34a refrigerant and lubricant. The lubricant has rapid moisture absorbing qualities.
2. Drier replacement is very important and must be changed when a system is opened for servicing.
3. Micron level vacuums must be achieved to insure low moisture levels in the system.
4. Compressor must be obtained through Atosa, unless otherwise specified in writing, through Atosa's warranty department.

What is Not Covered by This Warranty

Atosa's sole obligation under this warranty is limited to either repair or replacement of parts, subject to the additional limitations below. This warranty neither assumes nor authorizes any person to assume obligations other than those expressly covered by this warranty.

Routine Maintenance requirements must be followed or warranty is Void

NO CONSEQUENTIAL DAMAGES: ATOSA IS NOT RESPONSIBLE FOR ECONOMIC LOSS; PROFIT LOSS; OR SPECIAL, INDIRECT, OR CONSEQUENTIAL DAMAGES, INCLUDING WITHOUT LIMITATION, LOSSES, OR DAMAGES ARISING FROM FOOD OR PRODUCT SPOilage, REGARDLESS OF WHETHER OR NOT THEY RESULT FROM REFRIGERATION FAILURE.

WARRANTY IS NOT TRANSFERABLE: This warranty is not assignable and applies only in favor of the original purchaser/user to whom delivered. ANY SUCH ASSIGNMENT OR TRANSFER SHALL VOID THE WARRANTIES HEREIN AND SHALL VOID ALL WARRANTIES, EXPRESS OR IMPLIED, INCLUDING ANY WARRANTY OF MERCHANTABILITY OR LABOR COVERAGE FOR COMPONENT FAILURE OR OTHER THE WARRANTY PACKET PROVIDED WITH THE UNIT.

ALTERATION, NEGLIGENCE, ABUSE, MISUSE, ACCIDENT, DAMAGE DURING TRANSIT OR INSTALLATION, FIRE, FOOD, OR ACTS OF GOD:

Atosa is not responsible for the repair or replacement of any parts that are determined to have been subjected after the date of manufacture to alteration, neglect, abuse, misuse, accident, damage during transit or installation, fire, flood, or act of God.

IMPROPER ELECTRICAL CONNECTIONS: Atosa IS NOT RESPONSIBLE FOR THE REPAIR OR REPLACEMENT OF FAILED OR DAMAGED COMPONENTS RESULTING FROM ELECTRICAL POWER FAILURE, THE USE OF EXTENSION CORDS, LOW VOLTAGE, OR VOLTAGE DROPS TO THE UNIT.

THE TWO (2) YEAR PARTS & LABOR WARRANTY AND THE ADDITIONAL THREE (3) YEAR COMPRESSOR WARRANTY ARE AS DESCRIBED ABOVE. THESE WARRANTIES ARE EXCLUSIVE AND IN LIEU OF ALL OTHER WARRANTIES, INCLUDING IMPLIED WARRANTY AND MERCHANTABILITY OR FITNESS FOR A PARTICULAR PURPOSE. THERE ARE NO WARRANTIES WHICH EXTEND BEYOND THE DESCRIPTION ON THE FACE HEREOF.

Outside U.S. and Canada: This warranty does not apply to areas outside the continent of the United States. Atosa is not responsible for any warranty claims made on products sold or used in such areas.

In some cases, a 25% restocking fee may be charged to a buyer for returned items.



ATOSA CATERING EQUIPMENT INC.

WE ARE THE SPECICOOOLIST !

Toll Free:855-855-0399 Email:info@atosausa.com
www.atosa.com | www.atosausa.com

California, Colorado, Florida, Georgia, Illinois, Massachusetts, New Jersey, Ohio, Texas, Washington

Undercounter Freezer Series

Standard Features

- Exterior & interior stainless steel construction
- Heavy duty Embraco compressor
- Self-closing and stay open door
- Efficient refrigeration system
- Round corner design
- Recessed door handle
- Standard safety door lock
- Magnetic door gaskets
- Pre-installed castors
- Pre-installed shelves
- 155lbs loading capacity per shelf



MGF8405

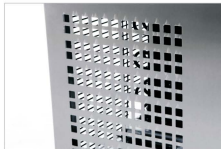

MGF8406



Specifications

Model	Doors	Cu.Ft	Shelves	Exterior Dimensions(W*D*H)	Packing Dimensions(W*D*H)	Castors	Gross Weight(LBS)	HP	Voltage	Amps	Refrigerant
MGF8405	1	6.5	1	27.48X30X37.16	30.3 X 33.6 X 38.2	5inch	178.2	1/3	115/60/1	4.1	R-134a
MGF8406	2	12	2	48.23X30X37.16	51.2 X 33.6 X 38.2	5inch	242.88	1/2	115/60/1	72	R-404a

For best results of food preservation, we recommend setting your freezer between 0°F - 8°F



2 YEARS WARRANTY ON ALL PARTS AND LABOR (US ONLY)
5 YEARS WARRANTY ON COMPRESSOR (US ONLY)



1. Don't forget to leave the unit some room to breathe!
2. Please clean the condenser frequently to give the unit more fresh air.



Plan View



Tenns and Conditions

2 YEAR WARRANTY

All claims for parts or labor must be made directly through Atosa. All claims must include: model number of the unit, the serial number, proof of purchase, date of installation, and all pertinent information supporting the alleged defect. In case of compressor replacement under warranty, either compressor or compressor tag must be returned to Atosa along with above listed information. **Failure to comply with warranty policies will result in voiding claims.**

Two Year Parts & Labor Warranty

Atosa warrants all new refrigerated components, such as the cabinet and all parts, to be free from defects in materials or workmanship. Atosa's obligation under this warranty is limited to a period of two (2) years from the date of original installation or 27 months after shipment date from Atosa, whichever occurs first. All parts covered under this warranty that are defective within two (2) years of original installation or twenty seven (27) months after shipment date from manufacturer, whichever occurs first, are limited to repair or replacement (including labor charges, of defective parts or assemblies). The labor warranty shall include standard straight time labor charges only and reasonable travel time, as determined by Atosa.

Additional Three Year Compressor Warranty

In addition to the two (2) year warranty stated above, Atosa warrants its sealed compressor to be free from defects in both material and workmanship under normal and proper use and maintenance service for a period of three (3) additional years from the date of original installation, but not to exceed five (5) years. Compressors that have been determined to be defective from Atosa within this extended period will be either repaired or replaced with a compressor or compressor parts of similar design and capacity according to Atosa's discretion. The three (3) year extended compressor warranty applies only to sealed parts of the compressor and does not apply to any other parts or components. This includes, the cabinet, paint finish, temperature control, refrigerant, metering device, motor starting equipment, fan assembly, and other electrical components, etc.

404A / 134a Compressor Warranty

The five-year compressor warranty detailed above will be void if the following procedure is not carefully adhered to:

1. This system contains R404A or RI 34a refrigerant and lubricant. The lubricant has rapid moisture absorbing qualities.
2. Drier replacement is very important and must be changed when a system is opened for servicing.
3. Micron level vacuums must be achieved to insure low moisture levels in the system.
4. Compressor must be obtained through Atosa, unless otherwise specified in writing, through Atosa's warranty department.

What is Not Covered by This Warranty

Atosa's sole obligation under this warranty is limited to either repair or replacement of parts, subject to the additional limitations below. This warranty neither assumes nor authorizes any person to assume obligations other than those expressly covered by this warranty.

Routine Maintenance requirements must be followed or warranty is Void

NO CONSEQUENTIAL DAMAGES: ATOSA IS NOT RESPONSIBLE FOR ECONOMIC LOSS; PROFIT LOSS; OR SPECIAL, INDIRECT, OR CONSEQUENTIAL DAMAGES, INCLUDING WITHOUT LIMITATION, LOSSES, OR DAMAGES ARISING FROM FOOD OR PRODUCT SPOilage, REGARDLESS OF WHETHER OR NOT THEY RESULT FROM REFRIGERATION FAILURE.

WARRANTY IS NOT TRANSFERABLE: This warranty is not assignable and applies only in favor of the original purchaser/user to whom delivered. ANY SUCH ASSIGNMENT OR TRANSFER SHALL VOID THE WARRANTIES HEREIN AND SHALL VOID ALL WARRANTIES, EXPRESS OR IMPLIED, INCLUDING ANY WARRANTY OF MERCHANTABILITY OR LABOR COVERAGE FOR COMPONENT FAILURE OR OTHER THE WARRANTY PACKET PROVIDED WITH THE UNIT.

ALTERATION, NEGLIGENCE, ABUSE, MISUSE, ACCIDENT, DAMAGE DURING TRANSIT OR INSTALLATION, FIRE, FOOD, OR ACTS OF GOD:

Atosa is not responsible for the repair or replacement of any parts that are determined to have been subjected after the date of manufacture to alteration, neglect, abuse, misuse, accident, damage during transit or installation, fire, flood, or act of God.

IMPROPER ELECTRICAL CONNECTIONS: Atosa IS NOT RESPONSIBLE FOR THE REPAIR OR REPLACEMENT OF FAILED OR DAMAGED COMPONENTS RESULTING FROM ELECTRICAL POWER FAILURE, THE USE OF EXTENSION CORDS, LOW VOLTAGE, OR VOLTAGE DROPS TO THE UNIT.

THE TWO (2) YEAR PARTS & LABOR WARRANTY AND THE ADDITIONAL THREE (3) YEAR COMPRESSOR WARRANTY ARE AS DESCRIBED ABOVE. THESE WARRANTIES ARE EXCLUSIVE AND IN LIEU OF ALL OTHER WARRANTIES, INCLUDING IMPLIED WARRANTY AND MERCHANTABILITY OR FITNESS FOR A PARTICULAR PURPOSE. THERE ARE NO WARRANTIES WHICH EXTEND BEYOND THE DESCRIPTION ON THE FACE HEREOF.

Outside U.S. and Canada: This warranty does not apply to areas outside the continent of the United States. Atosa is not responsible for any warranty claims made on products sold or used in such areas.

In some cases, a 25% restocking fee may be charged to a buyer for returned items.



ATOSA CATERING EQUIPMENT INC.

WE ARE THE SPECICOOOLIST !

Toll Free:855-855-0399 Email:info@atosausa.com
www.atosa.com | www.atosausa.com

California, Colorado, Florida, Georgia, Illinois, Massachusetts, New Jersey, Ohio, Texas, Washington

Sandwich Prep Table Refrigerator Series

Standard Features

- Front breathing, side mount compressor unit
- Exterior & interior stainless steel construction
- Stainless steel food pan included
- Heavy duty Embraco compressor
- Self-closing and stay open door
- Efficient refrigeration system
- Round corner design
- Recessed door handle
- Standard safety door lock
- Magnetic door gaskets
- Pre-installed castors
- Pre-installed shelves
- 155lbs loading capacity per shelf



Specifications

Model	Doors	Cu.Ft	Shelves	Exterior Dimensions(WD*H)	Packing Dimensions(WD*H)	Castors	Gross Weight(LBS)	HP	Voltage	Amps	Refrigerant
MSF8301	1	6.5	1	27.48 X 30 X 44.26	30.3 X 33.6 X 46.1	5inch	200.64	1/4	115/60/1	4.2	R-134a
MSF8302	2	12	2	48.23 X 30 X 44.26	51.2 X 33.6 X 46.1	5inch	281.16	1/3	115/60/1	6.5	R-134a
MSF8303	2	18.2	2	60.24 X 30 X 44.26	63.0 X 33.6 X 46.1	5inch	326.48	1/3	115/60/1	6.5	R-134a
MSF8304	3	32.8	3	72.68 X 30 X 44.26	75.5 X 33.6 X 46.1	5inch	388.08	1/3	115/60/1	7.5	R-134a

For best results of food preservation, we recommend setting your refrigerator between 33 °F - 38°F



2 YEARS WARRANTY ON ALL PARTS AND LABOR (US ONLY)
5 YEARS WARRANTY ON COMPRESSOR (US ONLY)



1. Don't forget to leave the unit some room to breathe!
2. Please clean the condenser frequently to give the unit more fresh air.



Plan View

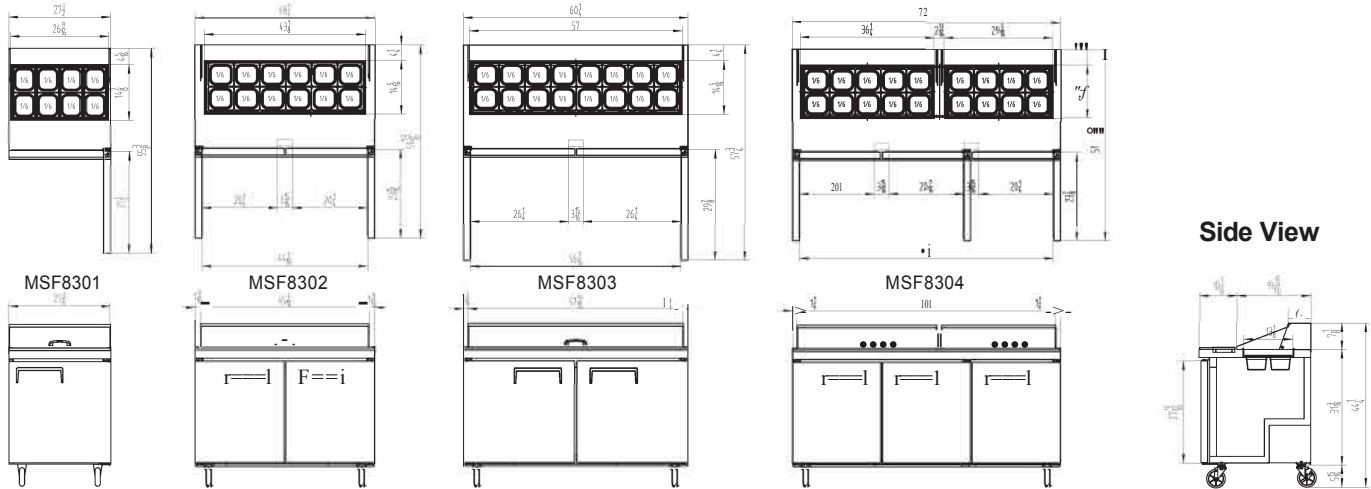

Tenns and Conditions

2 YEAR WARRANTY

All claims for parts or labor must be made directly through Atosa. All claims must include: model number of the unit, the serial number, proof of purchase, date of installation, and all pertinent information supporting the alleged defect. In case of compressor replacement under warranty, either compressor or compressor tag must be returned to Atosa along with above listed information. **Failure to comply with warranty policies will result in voiding claims.**

Two Year Parts & Labor Warranty

Atosa warrants all new refrigerated components, such as the cabinet and all parts, to be free from defects in materials or workmanship. Atosa's obligation under this warranty is limited to a period of two (2) years from the date of original installation or 27 months after shipment date from Atosa, whichever occurs first. All parts covered under this warranty that are defective within two (2) years of original installation or twenty seven (27) months after shipment date from manufacturer, whichever occurs first, are limited to repair or replacement (including labor charges, of defective parts or assemblies). The labor warranty shall include standard straight time labor charges only and reasonable travel time, as determined by Atosa.

Additional Three Year Compressor Warranty

In addition to the two (2) year warranty stated above, Atosa warrants its sealed compressor to be free from defects in both material and workmanship under normal and proper use and maintenance service for a period of three (3) additional years from the date of original installation, but not to exceed five (5) years. Compressors that have been determined to be defective from Atosa within this extended period will be either repaired or replaced with a compressor or compressor parts of similar design and capacity according to Atosa's discretion. The three (3) year extended compressor warranty applies only to sealed parts of the compressor and does not apply to any other parts or components. This includes, the cabinet, paint finish, temperature control, refrigerant, metering device, motor starting equipment, fan assembly, and other electrical components, etc.

404A / 134a Compressor Warranty

The five-year compressor warranty detailed above will be void if the following procedure is not carefully adhered to:

1. This system contains R404A or RI 34a refrigerant and lubricant. The lubricant has rapid moisture absorbing qualities.
2. Drier replacement is very important and must be changed when a system is opened for servicing.
3. Micron level vacuums must be achieved to insure low moisture levels in the system.
4. Compressor must be obtained through Atosa, unless otherwise specified in writing, through Atosa's warranty department.

What is Not Covered by This Warranty

Atosa's sole obligation under this warranty is limited to either repair or replacement of parts, subject to the additional limitations below. This warranty neither assumes nor authorizes any person to assume obligations other than those expressly covered by this warranty.

Routine Maintenance requirements must be followed or warranty is Void

NO CONSEQUENTIAL DAMAGES: ATOSA IS NOT RESPONSIBLE FOR ECONOMIC LOSS; PROFIT LOSS; OR SPECIAL, INDIRECT, OR CONSEQUENTIAL DAMAGES, INCLUDING WITHOUT LIMITATION, LOSSES, OR DAMAGES ARISING FROM FOOD OR PRODUCT SPOilage, REGARDLESS OF WHETHER OR NOT THEY RESULT FROM REFRIGERATION FAILURE.

WARRANTY IS NOT TRANSFERABLE: This warranty is not assignable and applies only in favor of the original purchaser/user to whom delivered. ANY SUCH ASSIGNMENT OR TRANSFER SHALL VOID THE WARRANTIES HEREIN AND SHALL VOID ALL WARRANTIES, EXPRESS OR IMPLIED, INCLUDING ANY WARRANTY OF MERCHANTABILITY OR LABOR COVERAGE FOR COMPONENT FAILURE OR OTHER THE WARRANTY PACKET PROVIDED WITH THE UNIT.

ALTERATION, NEGLIGENCE, ABUSE, MISUSE, ACCIDENT, DAMAGE DURING TRANSIT OR INSTALLATION, FIRE, FOOD, OR ACTS OF GOD:

Atosa is not responsible for the repair or replacement of any parts that are determined to have been subjected after the date of manufacture to alteration, neglect, abuse, misuse, accident, damage during transit or installation, fire, flood, or act of God.

IMPROPER ELECTRICAL CONNECTIONS: Atosa IS NOT RESPONSIBLE FOR THE REPAIR OR REPLACEMENT OF FAILED OR DAMAGED COMPONENTS RESULTING FROM ELECTRICAL POWER FAILURE, THE USE OF EXTENSION CORDS, LOW VOLTAGE, OR VOLTAGE DROPS TO THE UNIT.

THE TWO (2) YEAR PARTS & LABOR WARRANTY AND THE ADDITIONAL THREE (3) YEAR COMPRESSOR WARRANTY ARE AS DESCRIBED ABOVE. THESE WARRANTIES ARE EXCLUSIVE AND IN LIEU OF ALL OTHER WARRANTIES, INCLUDING IMPLIED WARRANTY AND MERCHANTABILITY OR FITNESS FOR A PARTICULAR PURPOSE. THERE ARE NO WARRANTIES WHICH EXTEND BEYOND THE DESCRIPTION ON THE FACE HEREOF.

Outside U.S. and Canada: This warranty does not apply to areas outside the continent of the United States. Atosa is not responsible for any warranty claims made on products sold or used in such areas.

In some cases, a 25% restocking fee may be charged to a buyer for returned items.



ATOSA CATERING EQUIPMENT INC.

WE ARE THE SPECICOOOLIST !

Toll Free:855-855-0399 Email:info@atosausa.com
www.atosa.com | www.atosausa.com

California, Colorado, Florida, Georgia, Illinois, Massachusetts, New Jersey, Ohio, Texas, Washington

Mega Top Sandwich Prep Table Refrigerator Series

Standard Features

- Front breathing, side mount compressor unit
- Exterior & interior stainless steel construction
- Stainless steel food pan included
- Heavy duty Embraco compressor
- Self-closing and stay open door
- Efficient refrigeration system
- Round corner design
- Recessed door handle
- Standard safety door lock
- Magnetic door gaskets
- Pre-installed castors
- Pre-installed shelves
- 155lbs loading capacity per shelf



MSF8305



MSF8306



MSF8307



MSF8308

Specifications

Model	Doors	Cu.Ft	Shelves	Exterior Dimensions(W*D*H)	Packing Dimensions(W*D*H)	Castors	Gross Weight(LBS)	HP	Voltage	Amps	Refrigerant
MSF8305	1	7.9	1	27.48 X 33.98 X 47.14	30.3 X 33.6 X 48.5	5inch	217.8	1/4	115/60/1	4.2	R-134a
MSF8306	2	14.7	2	48.23 X 33.98 X 47.14	51.2 X 33.6 X 48.5	5inch	302.28	1/3	115/60/1	6.5	R-134a
MSF8307	2	18.6	2	60.24 X 33.98 X 47.14	63.0 X 33.6 X 48.5	5inch	351.56	1/3	115/60/1	6.5	R-134a
MSF8308	3	22.6	3	72.68 X 33.98 X 47.14	75.5 X 33.6 X 48.5	5inch	417.12	1/3	115/60/1	7.5	R-134a

For best results of food preservation, we recommend setting your refrigerator between 33 °F - 38°F



2 YEARS WARRANTY ON ALL PARTS AND LABOR (US ONLY)
5 YEARS WARRANTY ON COMPRESSOR (US ONLY)



1. Don't forget to leave the unit some room to breathe!
2. Please clean the condenser frequently to give the unit more fresh air.



Plan View

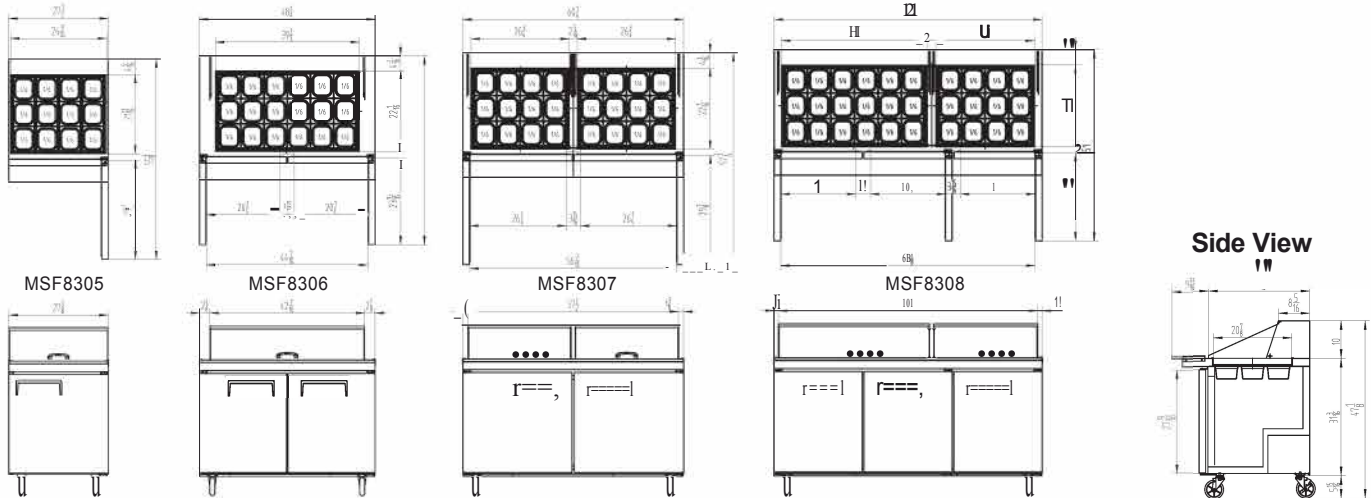

Tenns and Conditions

2 YEAR WARRANTY

All claims for parts or labor must be made directly through Atosa. All claims must include: model number of the unit, the serial number, proof of purchase, date of installation, and all pertinent information supporting the alleged defect. In case of compressor replacement under warranty, either compressor or compressor tag must be returned to Atosa along with above listed information. **Failure to comply with warranty policies will result in voiding claims.**

Two Year Parts & Labor Warranty

Atosa warrants all new refrigerated components, such as the cabinet and all parts, to be free from defects in materials or workmanship. Atosa's obligation under this warranty is limited to a period of two (2) years from the date of original installation or 27 months after shipment date from Atosa, whichever occurs first. All parts covered under this warranty that are defective within two (2) years of original installation or twenty seven (27) months after shipment date from manufacturer, whichever occurs first, are limited to repair or replacement (including labor charges, of defective parts or assemblies). The labor warranty shall include standard straight time labor charges only and reasonable travel time, as determined by Atosa.

Additional Three Year Compressor Warranty

In addition to the two (2) year warranty stated above, Atosa warrants its sealed compressor to be free from defects in both material and workmanship under normal and proper use and maintenance service for a period of three (3) additional years from the date of original installation, but not to exceed five (5) years. Compressors that have been determined to be defective from Atosa within this extended period will be either repaired or replaced with a compressor or compressor parts of similar design and capacity according to Atosa's discretion. The three (3) year extended compressor warranty applies only to sealed parts of the compressor and does not apply to any other parts or components. This includes, the cabinet, paint finish, temperature control, refrigerant, metering device, motor starting equipment, fan assembly, and other electrical components, etc.

404A / 134a Compressor Warranty

The five-year compressor warranty detailed above will be void if the following procedure is not carefully adhered to:

1. This system contains R404A or RI 34a refrigerant and lubricant. The lubricant has rapid moisture absorbing qualities.
2. Drier replacement is very important and must be changed when a system is opened for servicing.
3. Micron level vacuums must be achieved to insure low moisture levels in the system.
4. Compressor must be obtained through Atosa, unless otherwise specified in writing, through Atosa's warranty department.

What is Not Covered by This Warranty

Atosa's sole obligation under this warranty is limited to either repair or replacement of parts, subject to the additional limitations below. This warranty neither assumes nor authorizes any person to assume obligations other than those expressly covered by this warranty.

Routine Maintenance requirements must be followed or warranty is Void

NO CONSEQUENTIAL DAMAGES: ATOSA IS NOT RESPONSIBLE FOR ECONOMIC LOSS; PROFIT LOSS; OR SPECIAL, INDIRECT, OR CONSEQUENTIAL DAMAGES, INCLUDING WITHOUT LIMITATION, LOSSES, OR DAMAGES ARISING FROM FOOD OR PRODUCT SPOilage, REGARDLESS OF WHETHER OR NOT THEY RESULT FROM REFRIGERATION FAILURE.

WARRANTY IS NOT TRANSFERABLE: This warranty is not assignable and applies only in favor of the original purchaser/user to whom delivered. ANY SUCH ASSIGNMENT OR TRANSFER SHALL VOID THE WARRANTIES HEREIN AND SHALL VOID ALL WARRANTIES, EXPRESS OR IMPLIED, INCLUDING ANY WARRANTY OF MERCHANTABILITY OR LABOR COVERAGE FOR COMPONENT FAILURE OR OTHER THE WARRANTY PACKET PROVIDED WITH THE UNIT.

ALTERATION, NEGLIGENCE, ABUSE, MISUSE, ACCIDENT, DAMAGE DURING TRANSIT OR INSTALLATION, FIRE, FOOD, OR ACTS OF GOD:

Atosa is not responsible for the repair or replacement of any parts that are determined to have been subjected after the date of manufacture to alteration, neglect, abuse, misuse, accident, damage during transit or installation, fire, flood, or act of God.

IMPROPER ELECTRICAL CONNECTIONS: Atosa IS NOT RESPONSIBLE FOR THE REPAIR OR REPLACEMENT OF FAILED OR DAMAGED COMPONENTS RESULTING FROM ELECTRICAL POWER FAILURE, THE USE OF EXTENSION CORDS, LOW VOLTAGE, OR VOLTAGE DROPS TO THE UNIT.

THE TWO (2) YEAR PARTS & LABOR WARRANTY AND THE ADDITIONAL THREE (3) YEAR COMPRESSOR WARRANTY ARE AS DESCRIBED ABOVE. THESE WARRANTIES ARE EXCLUSIVE AND IN LIEU OF ALL OTHER WARRANTIES, INCLUDING IMPLIED WARRANTY AND MERCHANTABILITY OR FITNESS FOR A PARTICULAR PURPOSE. THERE ARE NO WARRANTIES WHICH EXTEND BEYOND THE DESCRIPTION ON THE FACE HEREOF.

Outside U.S. and Canada: This warranty does not apply to areas outside the continent of the United States. Atosa is not responsible for any warranty claims made on products sold or used in such areas.

In some cases, a 25% restocking fee may be charged to a buyer for returned items.



ATOSA CATERING EQUIPMENT INC.

WE ARE THE SPECICOOOLIST !

Toll Free:855-855-0399 Email:info@atosausa.com
www.atosa.com | www.atosausa.com

California, Colorado, Florida, Georgia, Illinois, Massachusetts, New Jersey, Ohio, Texas, Washington

Pizza Prep Table Refrigerator Series

Standard Features

- Exterior & interior stainless steel construction
- Stainless steel food pan included
- Heavy duty Embraco compressor
- Self-closing and stay open door
- Efficient refrigeration system
- Round corner design
- Recessed door handle
- Standard safety door lock
- Magnetic door gaskets
- Pre-installed castors
- Pre-installed shelves
- 155lbs loading capacity per shelf

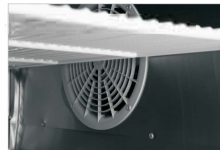

MPF8201



MPF8202



MPF8203



Specifications

Model	Doors	Cu.Ft	Shelves	Exterior Dimensions(W*D*H)	Packing Dimensions(W*D*H)	Castors	Gross Weight(LBS)	HP	Voltage	Amps	Refrigerant
MPF8201	1	14	2	43.98 X 33.07 X 44.03	46.9 X 35.5 X 45.7	5inch	302.5	1/4	115/60/1	4.2	R-134a
MPF8202	2	20	4	67.01 X 30 X 44.03	70.1 X 35.5 X 45.7	5inch	416.24	1/3	115/60/1	7.5	R-134a
MPF8203	3	26	6	92.99 X 30 X 44.03	96.1 X 35.5 X 45.7	5inch	540.32	2/3	115/60/1	7.7	R-134a

For best results of food preservation, we recommend setting your refrigerator between 33 'F - 38'F



2 YEARS WARRANTY ON ALL PARTS AND LABOR (US ONLY)
5 YEARS WARRANTY ON COMPRESSOR (US ONLY)



1. Don't forget to leave the unit some room to breathe!
2. Please clean the condenser frequently to give the unit more fresh air.



Plan View

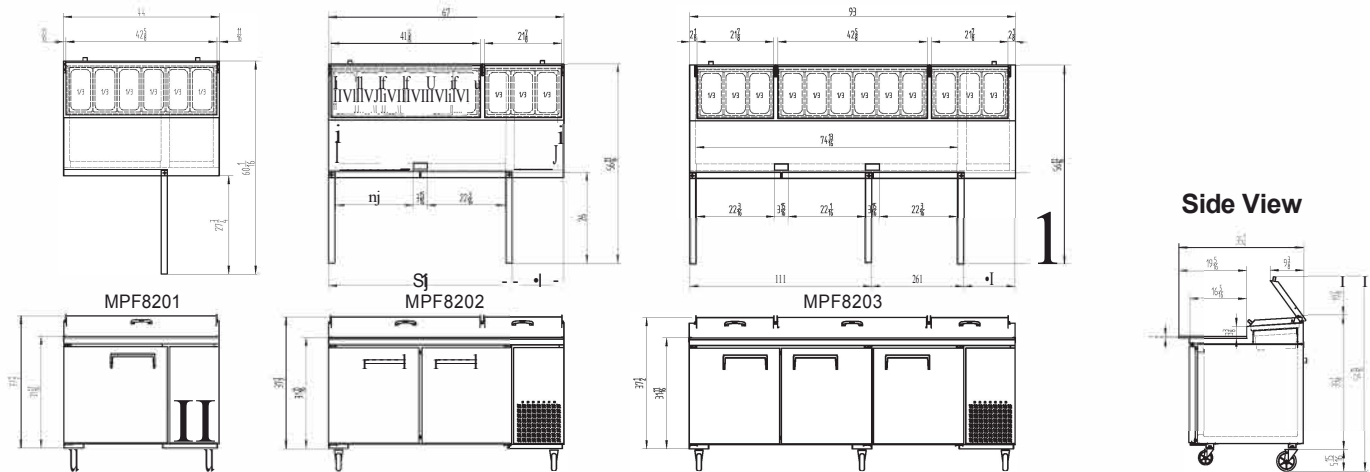

Tenns and Conditions

2 YEAR WARRANTY

All claims for parts or labor must be made directly through Atosa. All claims must include: model number of the unit, the serial number, proof of purchase, date of installation, and all pertinent information supporting the alleged defect. In case of compressor replacement under warranty, either compressor or compressor tag must be returned to Atosa along with above listed information. **Failure to comply with warranty policies will result in voiding claims.**

Two Year Parts & Labor Warranty

Atosa warrants all new refrigerated components, such as the cabinet and all parts, to be free from defects in materials or workmanship. Atosa's obligation under this warranty is limited to a period of two (2) years from the date of original installation or 27 months after shipment date from Atosa, whichever occurs first. All parts covered under this warranty that are defective within two (2) years of original installation or twenty seven (27) months after shipment date from manufacturer, whichever occurs first, are limited to repair or replacement (including labor charges, of defective parts or assemblies). The labor warranty shall include standard straight time labor charges only and reasonable travel time, as determined by Atosa.

Additional Three Year Compressor Warranty

In addition to the two (2) year warranty stated above, Atosa warrants its sealed compressor to be free from defects in both material and workmanship under normal and proper use and maintenance service for a period of three (3) additional years from the date of original installation, but not to exceed five (5) years. Compressors that have been determined to be defective from Atosa within this extended period will be either repaired or replaced with a compressor or compressor parts of similar design and capacity according to Atosa's discretion. The three (3) year extended compressor warranty applies only to sealed parts of the compressor and does not apply to any other parts or components. This includes, the cabinet, paint finish, temperature control, refrigerant, metering device, motor starting equipment, fan assembly, and other electrical components, etc.

404A / 134a Compressor Warranty

The five-year compressor warranty detailed above will be void if the following procedure is not carefully adhered to:

1. This system contains R404A or RI 34a refrigerant and lubricant. The lubricant has rapid moisture absorbing qualities.
2. Drier replacement is very important and must be changed when a system is opened for servicing.
3. Micron level vacuums must be achieved to insure low moisture levels in the system.
4. Compressor must be obtained through Atosa, unless otherwise specified in writing, through Atosa's warranty department.

What is Not Covered by This Warranty

Atosa's sole obligation under this warranty is limited to either repair or replacement of parts, subject to the additional limitations below. This warranty neither assumes nor authorizes any person to assume obligations other than those expressly covered by this warranty.

Routine Maintenance requirements must be followed or warranty is Void

NO CONSEQUENTIAL DAMAGES: ATOSA IS NOT RESPONSIBLE FOR ECONOMIC LOSS; PROFIT LOSS; OR SPECIAL, INDIRECT, OR CONSEQUENTIAL DAMAGES, INCLUDING WITHOUT LIMITATION, LOSSES, OR DAMAGES ARISING FROM FOOD OR PRODUCT SPOilage, REGARDLESS OF WHETHER OR NOT THEY RESULT FROM REFRIGERATION FAILURE.

WARRANTY IS NOT TRANSFERABLE: This warranty is not assignable and applies only in favor of the original purchaser/user to whom delivered. ANY SUCH ASSIGNMENT OR TRANSFER SHALL VOID THE WARRANTIES HEREIN AND SHALL VOID ALL WARRANTIES, EXPRESS OR IMPLIED, INCLUDING ANY WARRANTY OF MERCHANTABILITY OR LABOR COVERAGE FOR COMPONENT FAILURE OR OTHER THE WARRANTY PACKET PROVIDED WITH THE UNIT.

ALTERATION, NEGLIGENCE, ABUSE, MISUSE, ACCIDENT, DAMAGE DURING TRANSIT OR INSTALLATION, FIRE, FOOD, OR ACTS OF GOD:

Atosa is not responsible for the repair or replacement of any parts that are determined to have been subjected after the date of manufacture to alteration, neglect, abuse, misuse, accident, damage during transit or installation, fire, flood, or act of God.

IMPROPER ELECTRICAL CONNECTIONS: Atosa IS NOT RESPONSIBLE FOR THE REPAIR OR REPLACEMENT OF FAILED OR DAMAGED COMPONENTS RESULTING FROM ELECTRICAL POWER FAILURE, THE USE OF EXTENSION CORDS, LOW VOLTAGE, OR VOLTAGE DROPS TO THE UNIT.

THE TWO (2) YEAR PARTS & LABOR WARRANTY AND THE ADDITIONAL THREE (3) YEAR COMPRESSOR WARRANTY ARE AS DESCRIBED ABOVE. THESE WARRANTIES ARE EXCLUSIVE AND IN LIEU OF ALL OTHER WARRANTIES, INCLUDING IMPLIED WARRANTY AND MERCHANTABILITY OR FITNESS FOR A PARTICULAR PURPOSE. THERE ARE NO WARRANTIES WHICH EXTEND BEYOND THE DESCRIPTION ON THE FACE HEREOF.

Outside U.S. and Canada: This warranty does not apply to areas outside the continent of the United States. Atosa is not responsible for any warranty claims made on products sold or used in such areas.

In some cases, a 25% restocking fee may be charged to a buyer for returned items.



ATOSA CATERING EQUIPMENT INC.

WE ARE THE SPECICOOOLIST !

Toll Free:855-855-0399 Email:info@atosausa.com
www.atosa.com | www.atosausa.com

California, Colorado, Florida, Georgia, Illinois, Massachusetts, New Jersey, Ohio, Texas, Washington

Chef Base

Standard Features

- Stainless steel exterior and interior.
- Over sized, factory balanced refrigeration system using a heavy duty Embraco Compressor.
- Heavy duty stainless steel drawer slides and rollers; no tools required for drawer removal.
- Magnetic drawer gasket is removable for easy cleaning and maintenance.
- Recessed door handles.
- Pre-installed heavy duty casters with brakes, are included for added mobility.
- Designed with corrosion-resistant stainless steel of the highest quality.
- Cabinet top is one piece, heavy duty reinforced stainless steel to support countertop equipment.
- Gravity fed self closing drawers.



MGF8450
MGF8451



MGF8452



MGF8453



MGF8454

Specifications

Model	Description	Exterior Dimension			Packing Dimension			Pans in Each Drawers	Capacity (cuft)	Net Weight (lb)	Gross Weight (lb)	Voltage	Refrigerant	Power Consumption	AMPS	HP
		l"	W"	H"	l"	W"	H"									
MGF8450	48"Chef Base	48.4	32.1	26.6	51.1	35.2	28.7	1/1X2	9.4	213	260	115V/60HZ	R-134a	0.26KW	3.2	16
MGF8451	52"Chef Base	52.1	32.1	26.6	54.7	35.2	28.7	1/1X2 1/6X3	10.4	228	276	115V/60HZ	R-134a	0.26KW	3.2	16
MGF8452	60"Extended Top Chef Base	60.5	32.1	26.6	63.1	35.2	28.7	1/1 X2 1/6X3	10.4	235.4	285	115V/60HZ	R-134a	0.26KW	3.2	16
MGF8453	72"Chef Base	72.4	32.1	26.6	75.1	35.2	28.7	1/1X2	15	312.4	365	115V/60HZ	R-134a	0.36KW	4.2	14
MGF8454	76"Extended Top Chef Base	76	32.1	26.6	78.6	35.2	28.7	1/1X2	15	317	370	115V/60HZ	R-134a	0.36KW	4.2	14

The part number for pan guide is 84511905

For best results of food preservation, we recommend setting your refrigerator between 33°F - 38°F

Stainless Steel Food Pans Included



2 YEARS WARRANTY ON ALL PARTS AND LABOR (US ONLY)
5 YEARS WARRANTY ON COMPRESSOR (US ONLY)



• Atosa may at any time modify our equipment in order to provide and insure a superior product. Specifications subject to change without notice. Atosa reserves the final interpretation of all public materials.



Plan View

Side View

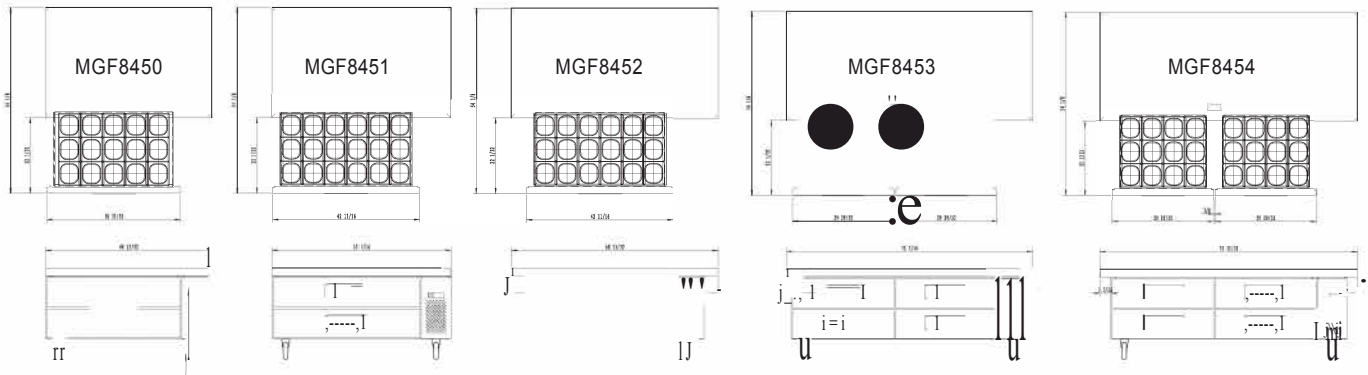

Tenns and Conditions

2 YEAR WARRANTY

All claims for parts or labor must be made directly through Atosa. All claims must include: model number of the unit, the serial number, proof of purchase, date of installation, and all pertinent information supporting the alleged defect. In case of compressor replacement under warranty, either compressor or compressor tag must be returned to Atosa along with above listed information. Failure to comply with warranty policies will result in voiding claims.

Two Year Parts & Labor Warranty

Atosa warrants all new refrigerated components, such as the cabinet and all parts, to be free from defects in materials or workmanship. Atosa's obligation under this warranty is limited to a period of two (2) years from the date of original installation or 27 months after shipment date from Atosa, whichever occurs first. All parts covered under this warranty that are defective within two (2) years of original installation or twenty seven (27) months after shipment date from manufacturer, whichever occurs first, are limited to repair or replacement (including labor charges, of defective parts or assemblies). The labor warranty shall include standard straight time labor charges only and reasonable travel time, as determined by Atosa.

Additional Three Year Compressor Warranty

In addition to the two (2) year warranty stated above, Atosa warrants its sealed compressor to be free from defects in both material and workmanship under normal and proper use and maintenance service for a period of three (3) additional years from the date of original installation, but not to exceed five (5) years. Compressors that have been determined to be defective from Atosa within this extended period will be either repaired or replaced with a compressor or compressor parts of similar design and capacity according to Atosa's discretion. The three (3) year extended compressor warranty applies only to sealed parts of the compressor and does not apply to any other parts or components. This includes, the cabinet, paint finish, temperature control, refrigerant, metering device, motor starting equipment, fan assembly, and other electrical components, etc.

404A / 134a Compressor Warranty

The five-year compressor warranty detailed above will be void if the following procedure is not carefully adhered to:

- 1. This system contains R404A or RI 34a refrigerant and lubricant. The lubricant has rapid moisture absorbing qualities.
2. Drier replacement is very important and must be changed when a system is opened for servicing.
3. Micron level vacuums must be achieved to insure low moisture levels in the system.
4. Compressor must be obtained through Atosa, unless otherwise specified in writing, through Atosa's warranty department.

What is Not Covered by This Warranty

Atosa's sole obligation under this warranty is limited to either repair or replacement of parts, subject to the additional limitations below. This warranty neither assumes nor authorizes any person to assume obligations other than those expressly covered by this warranty.

Routine Maintenance requirements must be followed or warranty is Void

NO CONSEQUENTIAL DAMAGES: ATOSA IS NOT RESPONSIBLE FOR ECONOMIC LOSS; PROFIT LOSS; OR SPECIAL, INDIRECT, OR CONSEQUENTIAL DAMAGES, INCLUDING WITHOUT LIMITATION, LOSSES, OR DAMAGES ARISING FROM FOOD OR PRODUCT SPOilage, REGARDLESS OF WHETHER OR NOT THEY RESULT FROM REFRIGERATION FAILURE.

WARRANTY IS NOT TRANSFERABLE: This warranty is not assignable and applies only in favor of the original purchaser/user to whom delivered. ANY SUCH ASSIGNMENT OR TRANSFER SHALL VOID THE WARRANTIES HEREIN AND SHALL VOID ALL WARRANTIES, EXPRESS OR IMPLIED, INCLUDING ANY WARRANTY OF MERCHANTABILITY OR LABOR COVERAGE FOR COMPONENT FAILURE OR OTHER THE WARRANTY PACKET PROVIDED WITH THE UNIT.

ALTERATION, NEGLIGENCE, ABUSE, MISUSE, ACCIDENT, DAMAGE DURING TRANSIT OR INSTALLATION, FIRE, FOOD, OR ACTS OF GOD:

Atosa is not responsible for the repair or replacement of any parts that are determined to have been subjected after the date of manufacture to alteration, neglect, abuse, misuse, accident, damage during transit or installation, fire, flood, or act of God.

IMPROPER ELECTRICAL CONNECTIONS: Atosa IS NOT RESPONSIBLE FOR THE REPAIR OR REPLACEMENT OF FAILED OR DAMAGED COMPONENTS RESULTING FROM ELECTRICAL POWER FAILURE, THE USE OF EXTENSION CORDS, LOW VOLTAGE, OR VOLTAGE DROPS TO THE UNIT.

THE TWO (2) YEAR PARTS & LABOR WARRANTY AND THE ADDITIONAL THREE (3) YEAR COMPRESSOR WARRANTY ARE AS DESCRIBED ABOVE. THESE WARRANTIES ARE EXCLUSIVE AND IN LIEU OF ALL OTHER WARRANTIES, INCLUDING IMPLIED WARRANTY AND MERCHANTABILITY OR FITNESS FOR A PARTICULAR PURPOSE. THERE ARE NO WARRANTIES WHICH EXTEND BEYOND THE DESCRIPTION ON THE FACE HEREOF.

Outside U.S. and Canada: This warranty does not apply to areas outside the continent of the United States. Atosa is not responsible for any warranty claims made on products sold or used in such areas.

In some cases, a 25% restocking fee may be charged to a buyer for returned items.

CookRite

CookRite offers a complete line of commercial cooking equipment. Perfect for any kitchen environment. Heavy duty gas Ranges made with exceptional durability and outstanding energy efficiency. In even the most demanding kitchen environments, our counter-top gas equipment will outperform our competition. Our char-broilers are made with reversible cast iron grates and our hotplates are constructed with burners that are built to last. All of our CookRite units are constructed with heavy duty stainless steel, giving it a clean and yet durable look. This line consists of heavy duty gas ranges, hot plates, griddles, char-broilers, stock pot stoves, deep fryers, cheese melters, salamander broilers. Available in both natural gas and liquid propane.



GAS EQUIPMENTS

Char Rock Broilers	25
Radiant Broilers	27
Griddles	29
HotPlates	31
Stock Pot Stoves	33
Fryers ■	35



TO COOK NICELY!

Toll Free: 855-855-0399 Email: info@atosausa.com
www.atosa.com | www.atosausa.com



GAS EQUIPMENTS

California, Colorado, Florida, Georgia, Illinois, Massachusetts, New Jersey, Ohio, Texas,
Washington

Char Rock Broilers

Standard Features

- Durable stainless steel structure, corrosion-resistant and easy to clean
- Simple and reasonable structure, easy to manipulate and maintain
- Highly efficient stainless steel burner standbys pilots
- Thick stainless steel radiant plates, for quick and even heating
- Cast iron grill to maintain the thermal inertia
- Independent manual controls to save the energy
- Adjustable multi-level top grates
- Adjustable stainless steel legs



ATCB-24



ATCB-36



ATCB-48

Specifications

Model	Burners and Control Method	Gas type	Intake-tube pressure (in.W.C.)	PerBTU/h	Total BTU/h	Regulator	ATCB Net Weight (LBS)Rock	Working Area(inch)	Packing Dimension (inch)	Gross Weight(LBS)
ATCB-24	2 Burners Independent Manual control	NG	4	35,000	70,000	4" w.c.	136.7	23.9X20.2	26.8X29.9X 18.2	168.2
		LP	10	35,000	70,000	10" w.c.				
ATCB-36	3 Burners Independent Manual control	NG	4	35,000	105,000	4" w.c.	190.52	35.7X20.2	38.6X29.9X 18.2	237.6
		LP	10	35,000	105,000	10" w.c.				
ATCB-48	4 Burners Independent Manual control	NG	4	35,000	140,000	4" w.c.	247.28	47.9X20.2	50.8X29.9X 18.2	313.7
		LP	10	35,000	140,000	10" w.c.				



1 YEAR PARTS AND LABOR WARRANTY



Conforms to ANSI
 STD Z83.11b-2009(2011)
 Certified to CSA
 STD 1.8b-2009(2011)
 Conforms to NSF/ANSI STD.4

Intertek Intertek
 4003935

Plan View

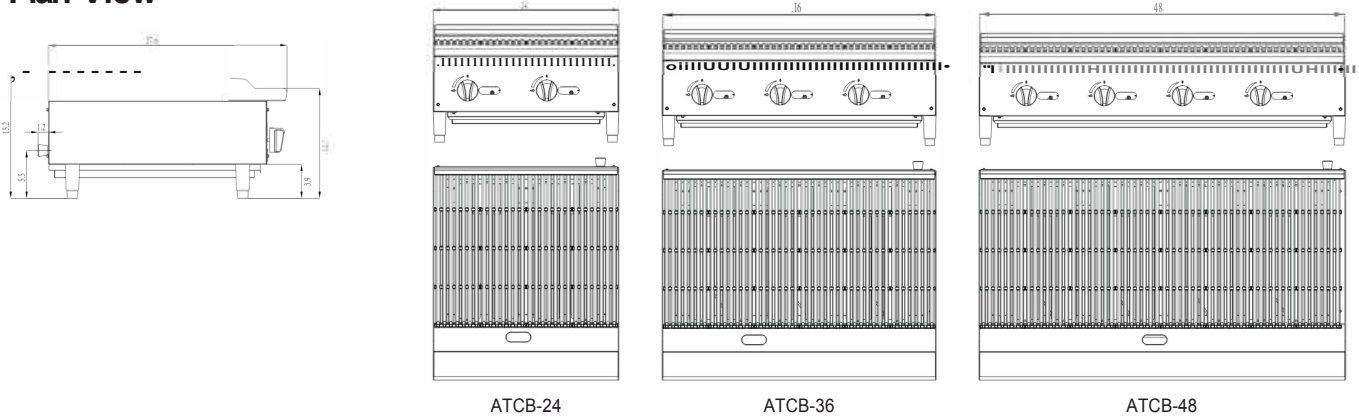

ATCB-24

ATCB-36

ATCB-48

Terms and Conditions

1 YEAR WARRANTY

All claims for parts or labor must be made directly to Atosa. All claims must include: model number of the unit, serial number, proof of purchase, date of installation, and all pertinent information supporting the alleged defect. Failure to comply with warranty policies will result in voiding claims.

Atosa warrants all new gas components to be free from defects in materials or workmanship. Atosa's obligation under this warranty is limited to a period of 1 year from the original installation. All parts covered under this warranty that are defective within 1 year of the original installation are limited to repair or replacement (Including labor charges, of defective parts or assemblies) The labor warranty shall include standard straight time labor charges only and reasonable travel time, as determined by Atosa.

NO CONSEQUENTIAL DAMAGES: ATOSA IS NOT RESPONSIBLE FOR ECONOMIC LOSS; PROFIT LOSS; OR SPECIAL, INDIRECT, OR CONSEQUENTIAL DAMAGES, INCLUDING WITHOUT LIMITATION, LOSSES, OR DAMAGES ARISING FROM FOOD OR PRODUCT SPOILAGE, REGARDLESS OF WHETHER OR NOT THEY RESULT FROM REFRIGERATION FAILURE.

WARRANTY IS NOT TRANSFERABLE: This warranty is not assignable and applies only in favor of the original purchaser/user to whom delivered. ANY SUCH ASSIGNMENT OR TRANSFER SHALL VOID THE WARRANTIES HEREIN AND SHALL VOID ALL WARRANTIES, EXPRESS OR IMPLIED, INCLUDING ANY WARRANTY OF MERCHANTABILITY OR LABOR COVERAGE FOR COMPONENT FAILURE OR OTHER THE WARRANTY PACKET PROVIDED WITH THE UNIT.

ALTERATION, NEGLIGENCE, ABUSE, MISUSE, ACCIDENT, DAMAGE DURING TRANSIT OR INSTALLATION, FIRE, FLOOD, OR ACTS OF GOD: Atosa is not responsible for the repair or replacement of any parts that are determined to have been subjected after the date of manufacture to alteration, neglect, abuse, misuse, accident, damage during transit or installation, fire, flood, or acts of God.

WHAT IS WARRANTED AND FOR HOW LONG:

The Product's cast-iron grates, stainless steel radiants, and briquettes are warranted not to fail as a result of defects in materials or workmanship in normal use for a period of one year from the date of purchase. Atosa agrees to repair or replace, at its option, the above warranted parts or items that fails due to defects in materials or workmanship during the warranted period. To obtain warranty service, the Purchaser must contact Atosa toll free (855) 855-0399

THE ONE YEAR PARTS & LABOR WARRANTY ARE AS DESCRIBED ABOVE. THESE WARRANTIES ARE EXCLUSIVE AND IN LIEU OF ALL OTHER WARRANTIES, INCLUDING IMPLIED WARRANTY AND MERCHANTABILITY OR FITNESS FOR A PARTICULAR PURPOSE. THERE ARE NO WARRANTIES WHICH EXTEND BEYOND THE DESCRIPTION ON THE FACE HEREOF.

Outside U.S. and Canada: This warranty does not apply to areas outside the continent of the United States. Atosa is not responsible for any warranty claims made on products sold or used in such areas.

In some cases, a 25% restocking fee may be charged to a buyer for returned items.

Radiant Broilers

Standard Features

- Durable stainless steel structure, corrosion-resistant and easy to clean
- Simple and reasonable structure, easy to manipulate and maintain
- Highly efficient stainless steel burner standbys pilots
- Thick stainless steel radiant plates, for quick and even heating
- Cast iron grill to maintain the thermal inertia
- Independent manual controls to save the energy
- Adjustable multi-level top grates
- Adjustable stainless steel legs



ATRC-24



ATRC-36



ATRC-48

Specifications

Model	Burners and Control Method	Gas type	Intake-tube pressure (in.W.C.)	Per BTU B.T.U/h	Total BTU B.T.U/h	Regulator	ATCB Net Weight (LBS)Rock	Working Area(inch)	Packing Dimension (inch)	Gross Weight(LBS)
ATRC-24	2 Burners Independent Manual control	NG	4	35,000	70,000	4" w.c.	116.6	23.9X20.2	26.8X29.9X18.2	146.6
		LP	10	35,000	70,000	10" w.c.				
ATRC-36	3 Burners Independent Manual control	NG	4	35,000	105,000	4" w.c.	158.4	35.7X20.2	38.6X29.9X18.2	205
		LP	10	35,000	105,000	10" w.c.				
ATRC-48	4 Burners Independent Manual control	NG	4	35,000	140,000	4" w.c.	200	47.9X20.2	50.8X29.9X18.2	256
		LP	10	35,000	140,000	10" w.c.				



1 YEAR PARTS AND LABOR WARRANTY



Conforms to ANSI
 STD Z83.11b-2009(2011)
 Certified to CSA
 STD 1.8b-2009(2011)
 Conforms to NSF/ANSI STD.4

Intertek Intertek
 4003935

Plan View

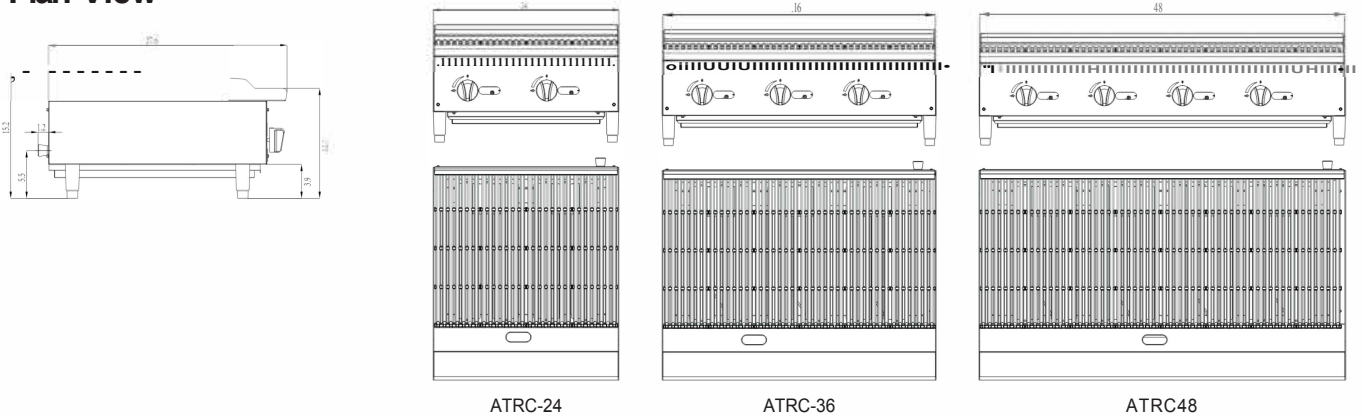

ATRC-24

ATRC-36

ATRC-48

Terms and Conditions

1 YEAR WARRANTY

All claims for parts or labor must be made directly to Atosa. All claims must include: model number of the unit, serial number, proof of purchase, date of installation, and all pertinent information supporting the alleged defect. Failure to comply with warranty policies will result in voiding claims.

Atosa warrants all new gas components to be free from defects in materials or workmanship. Atosa's obligation under this warranty is limited to a period of 1 year from the original installation. All parts covered under this warranty that are defective within 1 year of the original installation are limited to repair or replacement (Including labor charges, of defective parts or assemblies) The labor warranty shall include standard straight time labor charges only and reasonable travel time, as determined by Atosa.

NO CONSEQUENTIAL DAMAGES: ATOSA IS NOT RESPONSIBLE FOR ECONOMIC LOSS; PROFIT LOSS; OR SPECIAL, INDIRECT, OR CONSEQUENTIAL DAMAGES, INCLUDING WITHOUT LIMITATION, LOSSES, OR DAMAGES ARISING FROM FOOD OR PRODUCT SPOILAGE, REGARDLESS OF WHETHER OR NOT THEY RESULT FROM REFRIGERATION FAILURE.

WARRANTY IS NOT TRANSFERABLE: This warranty is not assignable and applies only in favor of the original purchaser/user to whom delivered. ANY SUCH ASSIGNMENT OR TRANSFER SHALL VOID THE WARRANTIES HEREIN AND SHALL VOID ALL WARRANTIES, EXPRESS OR IMPLIED, INCLUDING ANY WARRANTY OF MERCHANTABILITY OR LABOR COVERAGE FOR COMPONENT FAILURE OR OTHER THE WARRANTY PACKET PROVIDED WITH THE UNIT.

ALTERATION, NEGLIGENCE, ABUSE, MISUSE, ACCIDENT, DAMAGE DURING TRANSIT OR INSTALLATION, FIRE, FLOOD, OR ACTS OF GOD: Atosa is not responsible for the repair or replacement of any parts that are determined to have been subjected after the date of manufacture to alteration, neglect, abuse, misuse, accident, damage during transit or installation, fire, flood, or acts of God.

WHAT IS WARRANTED AND FOR HOW LONG:

The Product's cast-iron grates, stainless steel radiants, and briquettes are warranted not to fail as a result of defects in materials or workmanship in normal use for a period of one year from the date of purchase. Atosa agrees to repair or replace, at its option, the above warranted parts or items that fails due to defects in materials or workmanship during the warranted period. To obtain warranty service, the Purchaser must contact Atosa toll free (855) 855-0399

THE ONE YEAR PARTS & LABOR WARRANTY ARE AS DESCRIBED ABOVE. THESE WARRANTIES ARE EXCLUSIVE AND IN LIEU OF ALL OTHER WARRANTIES, INCLUDING IMPLIED WARRANTY AND MERCHANTABILITY OR FITNESS FOR A PARTICULAR PURPOSE. THERE ARE NO WARRANTIES WHICH EXTEND BEYOND THE DESCRIPTION ON THE FACE HEREOF.

Outside U.S. and Canada: This warranty does not apply to areas outside the continent of the United States. Atosa is not responsible for any warranty claims made on products sold or used in such areas.

In some cases, a 25% restocking fee may be charged to a buyer for returned items.

Griddles

Standard Features

- Durable stainless steel structure, corrosion-resistant and easy to clean
- Simple and reasonable structure, easy to manipulate and maintain
- Highly efficient stainless steel burner standbys pilots
- Thick grill, with excellent heat storage performance and even heating
- Independent manual controls to save the energy
- Adjustable stainless steel legs



ATMG-24



ATMG-36



ATMG-48

Specifications

Model	Burners and Control Method	Gas type	Intake-tube pressure (in.W.C.)	PerBTIJ B.T.U./h	Total BTU B.T.U/h	Regulator	ATCB Net Weight (LBS)Rock	Working Area(inch)	Packing Dimension (inch)	Gross Weight(LBS)
ATMG-24	2 Burners Independent Manual control	NG	4	30,000	60,000	4" w.c.	160.9	23.9X 19.9	26.8X31.1X 18.2	194.5
		LP	10	30,000	60,000	10" w.c.				
ATMG-36	3 Burners Independent Manual control	NG	4	30,000	90,000	4" w.c.	229	35.7X 19.9	38.6X31.1 X 18.2	280.9
		LP	10	30,000	90,000	10" w.c.				
ATMG-48	4 Burners Independent Manual control	NG	4	30,000	120,000	4" w.c.	294	47.9X 19.9	51.6X32.7X 17.6	414
		LP	10	30,000	120,000	10" w.c.				



1 YEAR PARTS AND LABOR WARRANTY



Conforms to ANSI
 STD Z83.11b-2009(2011)
 Certified to CSA
 STD 1.8b-2009(2011)
 Conforms to NSF/ANSI STD.4

Plan View

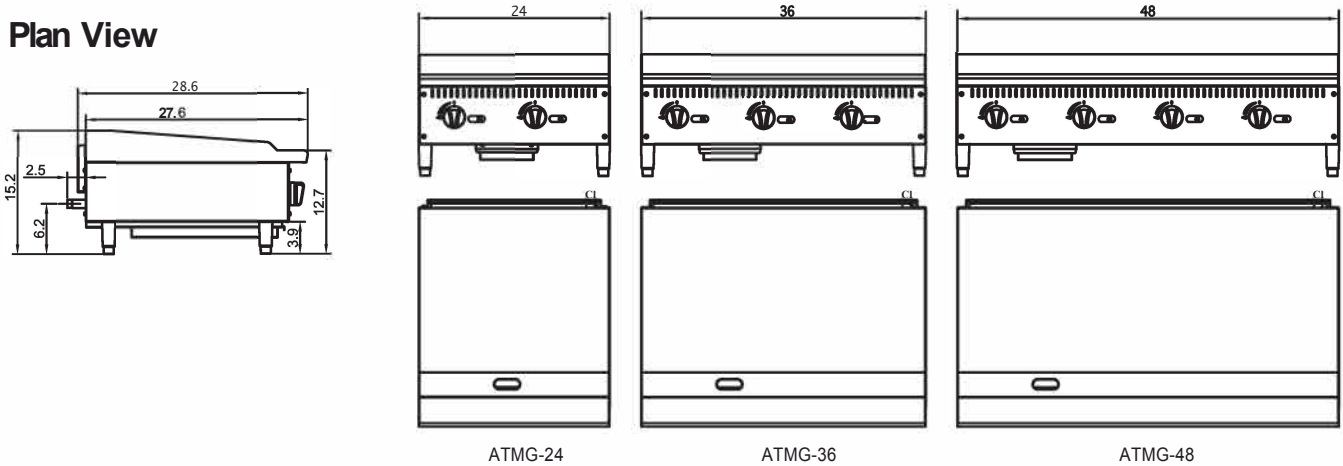

ATMG-24

ATMG-36

ATMG-48

Terms and Conditions

1 YEAR WARRANTY

All claims for parts or labor must be made directly to Atosa. All claims must include: model number of the unit, serial number, proof of purchase, date of installation, and all pertinent information supporting the alleged defect. Failure to comply with warranty policies will result in voiding claims.

Atosa warrants all new gas components to be free from defects in materials or workmanship. Atosa's obligation under this warranty is limited to a period of 1 year from the original installation. All parts covered under this warranty that are defective within 1 year of the original installation are limited to repair or replacement (Including labor charges, of defective parts or assemblies) The labor warranty shall include standard straight time labor charges only and reasonable travel time, as determined by Atosa.

NO CONSEQUENTIAL DAMAGES: ATOSA IS NOT RESPONSIBLE FOR ECONOMIC LOSS; PROFIT LOSS; OR SPECIAL, INDIRECT, OR CONSEQUENTIAL DAMAGES, INCLUDING WITHOUT LIMITATION, LOSSES, OR DAMAGES ARISING FROM FOOD OR PRODUCT SPOILAGE, REGARDLESS OF WHETHER OR NOT THEY RESULT FROM REFRIGERATION FAILURE.

WARRANTY IS NOT TRANSFERABLE: This warranty is not assignable and applies only in favor of the original purchaser/user to whom delivered. ANY SUCH ASSIGNMENT OR TRANSFER SHALL VOID THE WARRANTIES HEREIN AND SHALL VOID ALL WARRANTIES, EXPRESS OR IMPLIED, INCLUDING ANY WARRANTY OF MERCHANTABILITY OR LABOR COVERAGE FOR COMPONENT FAILURE OR OTHER THE WARRANTY PACKET PROVIDED WITH THE UNIT.

ALTERATION, NEGLIGENCE, ABUSE, MISUSE, ACCIDENT, DAMAGE DURING TRANSIT OR INSTALLATION, FIRE, FLOOD, OR ACTS OF GOD: Atosa is not responsible for the repair or replacement of any parts that are determined to have been subjected after the date of manufacture to alteration, neglect, abuse, misuse, accident, damage during transit or installation, fire, flood, or acts of God.

WHAT IS WARRANTED AND FOR HOW LONG:

The Product's cast-iron grates, stainless steel radiants, and briquettes are warranted not to fail as a result of defects in materials or workmanship in normal use for a period of one year from the date of purchase. Atosa agrees to repair or replace, at its option, the above warranted parts or items that fails due to defects in materials or workmanship during the warranted period. To obtain warranty service, the Purchaser must contact Atosa toll free (855) 855-0399

THE ONE YEAR PARTS & LABOR WARRANTY ARE AS DESCRIBED ABOVE. THESE WARRANTIES ARE EXCLUSIVE AND IN LIEU OF ALL OTHER WARRANTIES, INCLUDING IMPLIED WARRANTY AND MERCHANTABILITY OR FITNESS FOR A PARTICULAR PURPOSE. THERE ARE NO WARRANTIES WHICH EXTEND BEYOND THE DESCRIPTION ON THE FACE HEREOF.

Outside U.S. and Canada: This warranty does not apply to areas outside the continent of the United States. Atosa is not responsible for any warranty claims made on products sold or used in such areas.

In some cases, a 25% restocking fee may be charged to a buyer for returned items.

Hot Plates

Standard Features

- Durable stainless steel structure, corrosion-resistant and easy to clean
- Simple and reasonable structure, easy to manipulate and maintain
- Heavy duty burners, with stable flame, standby pilots
- Heavy duty Cast iron grates for a strong bearing performance
- Independent manual controls to save the energy
- Adjustable stainless steel legs



ATHP-12-2



ATHP-24-4



ATHP-36-6

Specifications

Model	Burners and Control Method	Gas type	Intake-tube pressure (in.W.C.)	Per BTU B.T.U./h	Total BTU B.T.U./h	Regulator	Netweight (LBS)	Packing Dimension (inch)	Gross Weight(LBS)
ATHP-12-2	2 Burners Independent Manual control	NG	4	25,000	50,000	4" w.c.	54	15X29.9X16.5	73.9
		LP	10	25,000	50,000	10" w.c.			
ATHP-24-4	4 Burners Independent Manual control	NG	4	25,000	100,000	4" w.c.	94	26.8X29.9X 16.5	124.6
		LP	10	25,000	100,000	10" w.c.			
ATHP-36-6	6 Burners Independent Manual control	NG	4	25,000	150,000	4" w.c.	134	38.6X29.9X 16.5	179.5
		LP	10	25,000	150,000	10" w.c.			



1 YEAR PARTS AND LABOR WARRANTY



Conforms to ANSI
 STD Z83.11b-2009(2011)
 Certified to CSA
 STD 1.8b-2009(2011)
 Conforms to NSF/ANSI STD.4

Intertek Intertek
 4003935

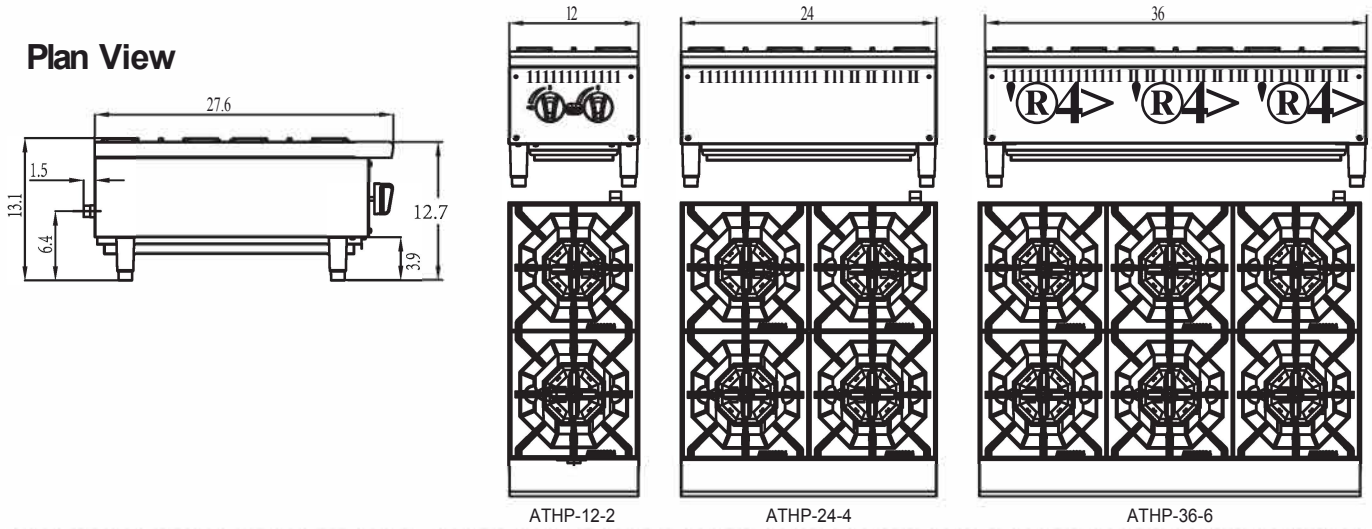

Terms and Conditions

1 YEAR WARRANTY

All claims for parts or labor must be made directly to Atosa. All claims must include: model number of the unit, serial number, proof of purchase, date of installation, and all pertinent information supporting the alleged defect. Failure to comply with warranty policies will result in voiding claims.

Atosa warrants all new gas components to be free from defects in materials or workmanship. Atosa's obligation under this warranty is limited to a period of 1 year from the original installation. All parts covered under this warranty that are defective within 1 year of the original installation are limited to repair or replacement (Including labor charges, of defective parts or assemblies) The labor warranty shall include standard straight time labor charges only and reasonable travel time, as determined by Atosa.

NO CONSEQUENTIAL DAMAGES: ATOSA IS NOT RESPONSIBLE FOR ECONOMIC LOSS; PROFIT LOSS; OR SPECIAL, INDIRECT, OR CONSEQUENTIAL DAMAGES, INCLUDING WITHOUT LIMITATION, LOSSES, OR DAMAGES ARISING FROM FOOD OR PRODUCT SPOILAGE, REGARDLESS OF WHETHER OR NOT THEY RESULT FROM REFRIGERATION FAILURE.

WARRANTY IS NOT TRANSFERABLE: This warranty is not assignable and applies only in favor of the original purchaser/user to whom delivered. ANY SUCH ASSIGNMENT OR TRANSFER SHALL VOID THE WARRANTIES HEREIN AND SHALL VOID ALL WARRANTIES, EXPRESS OR IMPLIED, INCLUDING ANY WARRANTY OF MERCHANTABILITY OR LABOR COVERAGE FOR COMPONENT FAILURE OR OTHER THE WARRANTY PACKET PROVIDED WITH THE UNIT.

ALTERATION, NEGLIGENCE, ABUSE, MISUSE, ACCIDENT, DAMAGE DURING TRANSIT OR INSTALLATION, FIRE, FLOOD, OR ACTS OF GOD: Atosa is not responsible for the repair or replacement of any parts that are determined to have been subjected after the date of manufacture to alteration, neglect, abuse, misuse, accident, damage during transit or installation, fire, flood, or acts of God.

WHAT IS WARRANTED AND FOR HOW LONG:

The Product's cast-iron grates, stainless steel radiants, and briquettes are warranted not to fail as a result of defects in materials or workmanship in normal use for a period of one year from the date of purchase. Atosa agrees to repair or replace, at its option, the above warranted parts or items that fails due to defects in materials or workmanship during the warranted period. To obtain warranty service, the Purchaser must contact Atosa toll free (855) 855-0399

THE ONE YEAR PARTS & LABOR WARRANTY ARE AS DESCRIBED ABOVE. THESE WARRANTIES ARE EXCLUSIVE AND IN LIEU OF ALL OTHER WARRANTIES, INCLUDING IMPLIED WARRANTY AND MERCHANTABILITY OR FITNESS FOR A PARTICULAR PURPOSE. THERE ARE NO WARRANTIES WHICH EXTEND BEYOND THE DESCRIPTION ON THE FACE HEREOF.

Outside U.S. and Canada: This warranty does not apply to areas outside the continent of the United States. Atosa is not responsible for any warranty claims made on products sold or used in such areas.

In some cases, a 25% restocking fee may be charged to a buyer for returned items.

Stock Pot Stoves

Standard Features

- NEW full width, removable stainless steel drip pan for easy cleanup
- Compact, heavy duty chassis for a long life span
- Stainless steel sides and front valve cover
- Stainless steel tubing for pilots
- One year limited warranty, parts and labor
- Heavy ,cast iron three- ring burner, rated at a total of 80,000 BTU/hr
- Burner is equipped with two continuous pilots strategically placed for instant ignitions of each section
- Two manual controls to operate the inner and outer rings independently, for maximum flexibility of usage
- Heavy duty cast iron top grate



ATSP-18-1



ATSP-18-1L



ATSP-18-2



ATSP-18-2L

Specifications

Model	Burners and Control Method	Gas type	Intake-tube pressure (in.W.C.)	Per BTU B.T.U./h	Total BTU B.T.U./h	Regulator	Netweight (LBS)	Packing Dimension (inch)	Gross Weight(LBS)
ATSP-18-1	2 Burner Independent Manual control	NG	4	40,000	80,000	4" w.c.	105.8	20.9X24.8X25	119
		LP	10	40,000	80,000	10" w.c.			
ATSP-18-2	4 Burners Independent Manual control	NG	4	40,000	160,000	4" w.c.	201.7	20.9X45.7X25	221.6
		LP	10	40,000	160,000	10" w.c.			
ATSP-18-1L	2 Burner Independent Manual control	NG	4	40,000	80,000	4" w.c.	103.4	20.9X24.8X20.1	116.8
		LP	10	40,000	80,000	10" w.c.			
ATSP-18-2L	4 Burners Independent Manual control	NG	4	40,000	160,000	4" w.c.	198	20.9X45.7X20.1	220
		LP	10	40,000	160,000	10" w.c.			



1 YEAR PARTS AND LABOR WARRANTY



Conforms to ANSI
 STD Z83.11b-2009(2011)
 Certified to CSA
 STD 1.8b-2009(2011)
 Conforms to NSF/ANSI STD.4

Intertek Intertek
 4003935

Plan View

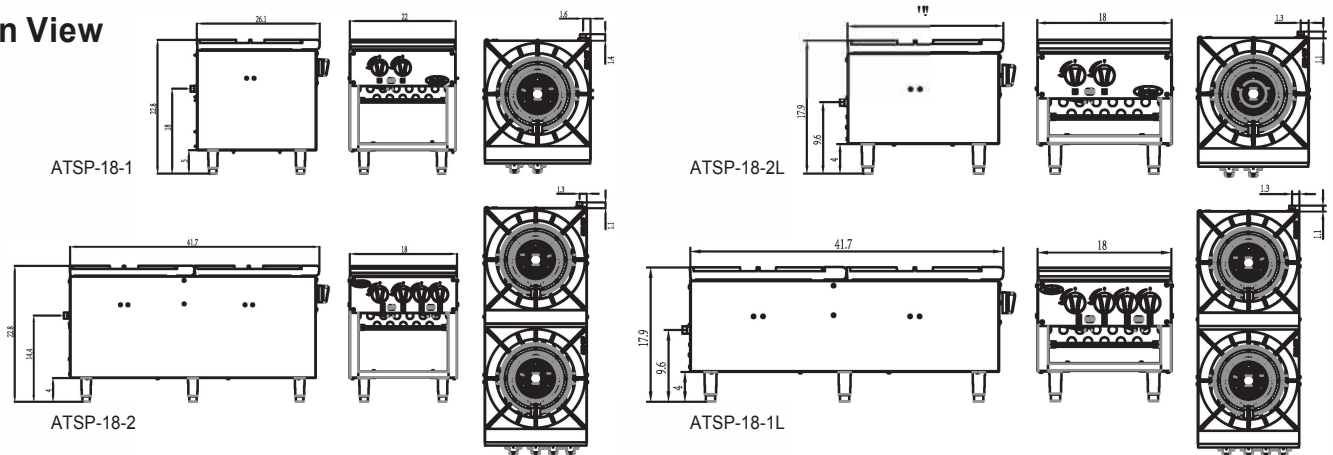

Terms and Conditions

1 YEAR WARRANTY

All claims for parts or labor must be made directly to Atosa. All claims must include: model number of the unit, serial number, proof of purchase, date of installation, and all pertinent information supporting the alleged defect. Failure to comply with warranty policies will result in voiding claims.

Atosa warrants all new gas components to be free from defects in materials or workmanship. Atosa's obligation under this warranty is limited to a period of 1 year from the original installation. All parts covered under this warranty that are defective within 1 year of the original installation are limited to repair or replacement (Including labor charges, of defective parts or assemblies) The labor warranty shall include standard straight time labor charges only and reasonable travel time, as determined by Atosa.

NO CONSEQUENTIAL DAMAGES: ATOSA IS NOT RESPONSIBLE FOR ECONOMIC LOSS; PROFIT LOSS; OR SPECIAL, INDIRECT, OR CONSEQUENTIAL DAMAGES, INCLUDING WITHOUT LIMITATION, LOSSES, OR DAMAGES ARISING FROM FOOD OR PRODUCT SPOILAGE, REGARDLESS OF WHETHER OR NOT THEY RESULT FROM REFRIGERATION FAILURE.

WARRANTY IS NOT TRANSFERABLE: This warranty is not assignable and applies only in favor of the original purchaser/user to whom delivered. ANY SUCH ASSIGNMENT OR TRANSFER SHALL VOID THE WARRANTIES HEREIN AND SHALL VOID ALL WARRANTIES, EXPRESS OR IMPLIED, INCLUDING ANY WARRANTY OF MERCHANTABILITY OR LABOR COVERAGE FOR COMPONENT FAILURE OR OTHER THE WARRANTY PACKET PROVIDED WITH THE UNIT.

ALTERATION, NEGLIGENCE, ABUSE, MISUSE, ACCIDENT, DAMAGE DURING TRANSIT OR INSTALLATION, FIRE, FLOOD, OR ACTS OF GOD: Atosa is not responsible for the repair or replacement of any parts that are determined to have been subjected after the date of manufacture to alteration, neglect, abuse, misuse, accident, damage during transit or installation, fire, flood, or acts of God.

WHAT IS WARRANTED AND FOR HOW LONG:

The Product's cast-iron grates, stainless steel radiants, and briquettes are warranted not to fail as a result of defects in materials or workmanship in normal use for a period of one year from the date of purchase. Atosa agrees to repair or replace, at its option, the above warranted parts or items that fails due to defects in materials or workmanship during the warranted period. To obtain warranty service, the Purchaser must contact Atosa toll free (855) 855-0399

THE ONE YEAR PARTS & LABOR WARRANTY ARE AS DESCRIBED ABOVE. THESE WARRANTIES ARE EXCLUSIVE AND IN LIEU OF ALL OTHER WARRANTIES, INCLUDING IMPLIED WARRANTY AND MERCHANTABILITY OR FITNESS FOR A PARTICULAR PURPOSE. THERE ARE NO WARRANTIES WHICH EXTEND BEYOND THE DESCRIPTION ON THE FACE HEREOF.

Outside U.S. and Canada: This warranty does not apply to areas outside the continent of the United States. Atosa is not responsible for any warranty claims made on products sold or used in such areas.

In some cases, a 25% restocking fee may be charged to a buyer for returned items.

Fryers

Standard Features

- Durable stainless steel structure, corrosion-resistant and easy to clean
- Simple and reasonable structure, easy to manipulate and maintain
- Heavy duty burners, with a stable flame, standby pilots
- Safety valve with an automatic voltage stabilizing function
- Imported high quality thermostat, temperature control between 93 °C-205 °C/200 °F-400 °F
- Self-reset high temperature limiting device
- Nickel plated baskets/includes wire mesh crumb screen
- Oil cooling zone seated in the bottom of the tank, to avoid the influence of food residue
- Adjustable stainless steel legs



ATFS-40



ATFS-50



ATFS-75

Specifications

Model	Burners and Control Method	Gas type	Intake-tube pressure (in.W.C.)	Per BTU B.T.U./h	Total BTU B.T.U./h	Regulator	Netweight (LBS)	Packing Dimension (inch)	Gross Weight(LBS)
ATFS-40	3 Burners Independent Manual control	NG	4	34,000	102,000	4" w.c.	131	17.7X33.5X37.9	159.6
		LP	10	30,000	90,000	10" w.c.			
ATFS-50	4 Burners Independent Manual control	NG	4	34,000	136,000	4" w.c.	143	17.7X33.5X37.9	171.1
		LP	10	30,000	120,000	10" w.c.			
ATFS-75	5 Burners Independent Manual control	NG	4	34,000	170,000	4" w.c.	168	23.2X33.5X37.9	199.5
		LP	10	30,000	150,000	10" w.c.			



1 YEAR PARTS AND LABOR WARRANTY
 5 YEARS OIL TANK WARRANTY



Conforms to ANSI
 STD Z83.11b-2009(2011)
 Certified to CSA
 STD 1.8b-2009(2011)
 Conforms to NSF/ANSI STD.4

Plan View

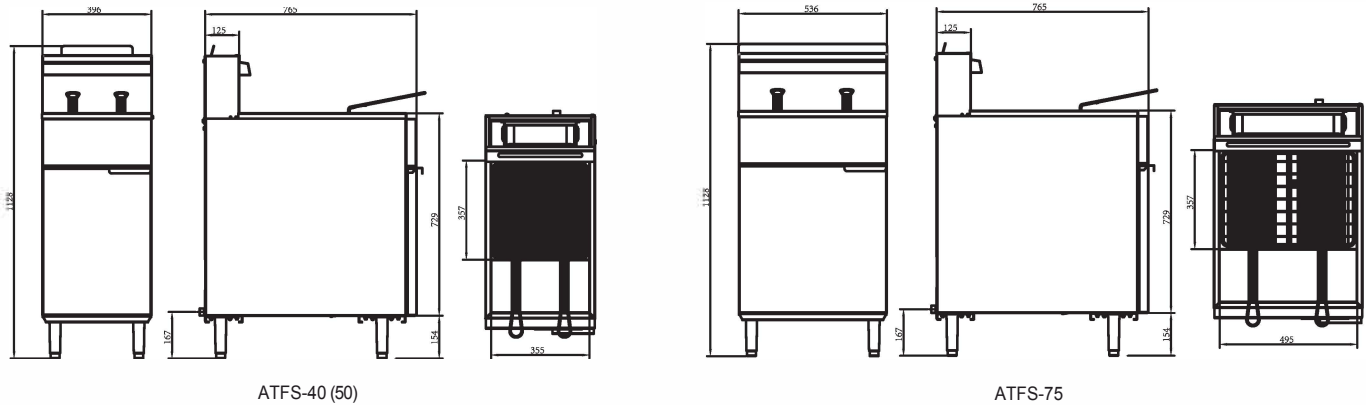

ATFS-40 (50)

ATFS-75

Terms and Conditions

WARRANTY

The stainless steel fry tank has a five (5) year limited tank warranty. If during the first year only, the tank is found to have a leak and is verified by an authorized service company, the entire fryer will be replaced. After the first year a replacement tank will be sent free of charge excluding freight and labor charges.

All claims for parts or labor must be made directly to Atosa. All claims must include: model number of the unit, serial number, proof of purchase, date of installation, and all pertinent information supporting the alleged defect. Failure to comply with warranty policies will result in voiding claims.

Atosa warrants all new gas components to be free from defects in materials or workmanship. Atosa's obligation under this warranty is limited to a period of 1 year from the original installation. All parts covered under this warranty that are defective within 1 year of the original installation are limited to repair or replacement (including labor charges, of defective parts or assemblies) The labor warranty shall include standard straight time labor charges only and reasonable travel time, as determined by Atosa.

NO CONSEQUENTIAL DAMAGES: ATOSA IS NOT RESPONSIBLE FOR ECONOMIC LOSS; PROFIT LOSS; OR SPECIAL, INDIRECT, OR CONSEQUENTIAL DAMAGES, INCLUDING WITHOUT LIMITATION, LOSSES, OR DAMAGES ARISING FROM FOOD OR PRODUCT SPOILAGE, REGARDLESS OF WHETHER OR NOT THEY RESULT FROM REFRIGERATION FAILURE.

WARRANTY IS NOT TRANSFERABLE: This warranty is not assignable and applies only in favor of the original purchaser/user to whom delivered. ANY SUCH ASSIGNMENT OR TRANSFER SHALL VOID THE WARRANTIES HEREIN AND SHALL VOID ALL WARRANTIES, EXPRESS OR IMPLIED, INCLUDING ANY WARRANTY OF MERCHANTABILITY OR LABOR COVERAGE FOR COMPONENT FAILURE OR OTHER THE WARRANTY PACKET PROVIDED WITH THE UNIT.

ALTERATION, NEGLIGENCE, ABUSE, MISUSE, ACCIDENT, DAMAGE DURING TRANSIT OR INSTALLATION, FIRE, FLOOD, OR ACTS OF GOD: Atosa is not responsible for the repair or replacement of any parts that are determined to have been subjected after the date of manufacture to alteration, neglect, abuse, misuse, accident, damage during transit or installation, fire, flood, or acts of God.

WHAT IS WARRANTED AND FOR HOW LONG:

The Product's cast-iron grates, stainless steel radiants, and briquettes are warranted not to fail as a result of defects in materials or workmanship in normal use for a period of one year from the date of purchase. Atosa agrees to repair or replace, at its option, the above warranted parts or items that fails due to defects in materials or workmanship during the warranted period. To obtain warranty service, the Purchaser must contact Atosa toll free (855) 855-0399

THE ONE YEAR PARTS & LABOR WARRANTY ARE AS DESCRIBED ABOVE. THESE WARRANTIES ARE EXCLUSIVE AND IN LIEU OF ALL OTHER WARRANTIES, INCLUDING IMPLIED WARRANTY AND MERCHANTABILITY OR FITNESS FOR A PARTICULAR PURPOSE. THERE ARE NO WARRANTIES WHICH EXTEND BEYOND THE DESCRIPTION ON THE FACE HEREOF.

Outside U.S. and Canada: This warranty does not apply to areas outside the continent of the United States. Atosa is not responsible for any warranty claims made on products sold or used in such areas.

In some cases, a 25% restocking fee may be charged to a buyer for returned items.

(MD<nce)

MixRite offers high quality stainless steel products. The products in this line are made for every day use, but are designed with exceptional craftsmanship. Our sinks are formed from a single sheet, fused and polished creating a one-piece sanitary unit. Just like the other Atosa products, MixRite offers a cosmetically beautiful appearance. This lines consists of food pans, work tables, equipment stands, and sinks.



SMALLWARES

Economic Chafers	37
Roll Top Chafers	39
Food Warmers	41
Stainless Steel Equipment Stands	43
Steam Table Pans	45

(MIXrICE)

MAKE THE STEEL RITE !

Toll Free:855-855-0399 Email:info@atosausa.com
www.atosa.com |www.atosausa.com



SMALLWARES

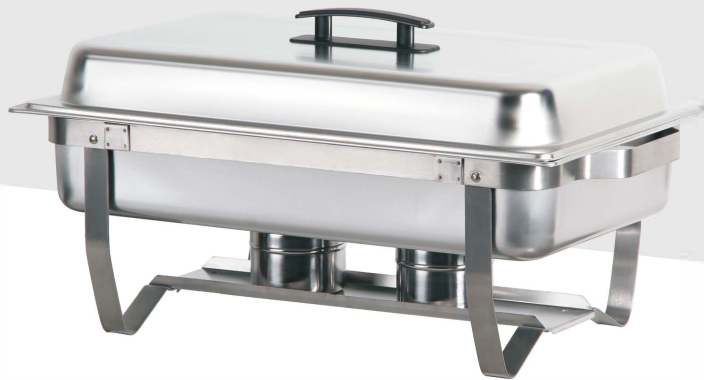

California, Colorado, Florida, Georgia, Illinois, Massachusetts, New Jersey, Ohio, Texas,
Washington

Economic Chafers

Standard Features

- Stainless steel stable frame and legs
- Heat resistant handle
- Water pan plus two burner holders
- Pre-installed full size by 4"deep food pan
- Polished Mirror Finish



AT751L63-1



AT761L63-1



AT721R61-1

Specifications

Model	Width	Depth	Height	Capacity	Color	CoverType	Material	Shape	Size	NetWeight	Gross Weight
AI751L63-1	22.8"	15"	11.8"	8qt.	Silver	Lift-Off	Stainless Steel	Rectangle	Full Size	9.28Lbs	11.49Lbs
AI761L63-1	23.6"	14.2"	11.8"	9qt.	Silver	Lift-Off	Stainless Steel	Rectangle	Full Size	9.48Lbs	11.68Lbs
AI721R61-1	23.6"	13.4"	14.6"	8qt.	Silver	Retractable	Stainless Steel	Rectangle	Full Size	18.36Lbs	20.57Lbs

Plan View

F1 A ffi

AT751L63-1	W:22.8'	D: 15'	H 11.8'
AT761L63-1	W:23.6'	D:14.2'	H 11.8'
AT721R61-1	W:23.6'	D: 13.4"	H 14.6'

Terms and Conditions

One Year Limited Warranty

Atosa Catering Equipment warrants its equipment against defects in materials and workmanship, subject to the following conditions: Atosa Catering Equipment is warranted for one year, effective from the date of purchase by the original owner. A copy of the original receipt or other proof of purchase is required to obtain warranty coverage. This warranty applies to the original owner only, and is nontransferable. Should any product fail to function in its intended manner under normal use within the limits defined in this warranty, at Atosa's discretion, such product will be replaced with a new unit by Atosa, after defective unit has been inspected. And defect has been confirmed. Atosa does not assume any liability for extended delays in replacing any item beyond its control. This warranty does not apply to plastic and non-metallic synthetic parts that may need to be replaced due to normal usage, or lack of preventative maintenance.

WHAT IS NOT COVERED BY THIS WARRANTY

- Equipment that has not properly been maintained, damage from improper cleaning, and water damage to controls.
- Equipment that has not been used in an appropriate manner, or has been subject to misuse, neglect, abuse, accident, alteration, negligence, damage during transit, fire, flood, or acts of God.

If the equipment has been changed, altered, modified, or repaired without express written permission from Atosa, then the manufacturer shall not be liable for any damages to any person or to any property, which may result from the use of this equipment thereafter.

For warranty and non-warranty related issues, technical support, purchase replacement parts contact Atosa toll free (855) 855-0399

*In some cases, a 25% restocking fee may be charged to a buyer for returned items.

Roll Top Chafers

Standard Features

- Stainless steel stable frame and legs
- Revolving cover opens gently
- Polished Mirror Finish
- Roll top cover adjustable 90° and 180°
- Water pan plus burner holder
- Pre-installed 4"deep round food pan
- Easily Change container without removing lid



AT751363

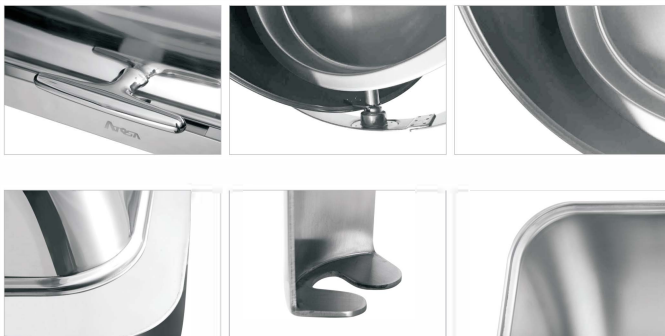

AT61363

Specifications

Model	Width	Depth	Height	Capacity	Color	Cover Type	Material	Shape	Size	Net Weight	Gross Weight
AT51363	19.7"	20.9"	17.7"	5qt.	Silver	Roll top	Stainless Steel	Round	Full Size	15.79Lbs	17.99Lbs
AT61363	25.4"	18.7"	17.1"	8.5qt.	Silver	Roll top	Stainless Steel	Oblong	Full Size	23.90Lbs	26.10Lbs

Plan View

AT51363



AT61363

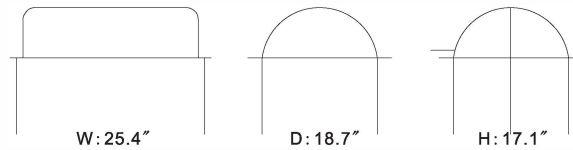

Terms and Conditions

One Year Limited Warranty

Atosa Catering Equipment warrants its equipment against defects in materials and workmanship, subject to the following conditions: Atosa Catering Equipment is warranted for one year, effective from the date of purchase by the original owner. A copy of the original receipt or other proof of purchase is required to obtain warranty coverage. This warranty applies to the original owner only, and is nontransferable. Should any product fail to function in its intended manner under normal use within the limits defined in this warranty, at Atosa's discretion, such product will be replaced with a new unit by Atosa, after defective unit has been inspected. And defect has been confirmed. Atosa does not assume any liability for extended delays in replacing any item beyond its control. This warranty does not apply to plastic and non-metallic synthetic parts that may need to be replaced due to normal usage, or lack of preventative maintenance.

WHAT IS NOT COVERED BY THIS WARRANTY

- Equipment that has not properly been maintained, damage from improper cleaning, and water damage to controls.
- Equipment that has not been used in an appropriate manner, or has been subject to misuse, neglect, abuse, accident, alteration, negligence, damage during transit, fire, flood, or acts of God.

If the equipment has been changed, altered, modified, or repaired without express written permission from Atosa, then the manufacturer shall not be liable for any damages to any person or to any property, which may result from the use of this equipment thereafter.

For warranty and non-warranty related issues, technical support, purchase replacement parts contact Atosa toll free (855) 855-0399

*In some cases, a 25% restocking fee may be charged to a buyer for returned items.

Food Warmers

Standard Features

7700

- Stainless steel structure
- Anti-drip well edge
- Lighted on/off switch
- Heat up within 10 minutes

AT51588
 AT51388

- Hinged stainless lid for easy serving
- Removable stainless inset



AT51588



AT51388



7700

Specifications

Model	Height	Diametr	Amps	Hertz	Voltage	wattage	Capacity	Capacity per Compartment	Control Type	Inset Included	Number of Compartments	Temperature	G : S	Gross Weight
AT51588	14"	14.2"	3.3Amps	60	120Volts	400Watts	11 qt.	11 qt.	Infinite	Yes	1	105-195° F	10.93Lbs	13.14Lbs

Model	Height	Diametr	Interior Height	Interior Diameter	Amps	Hertz	Voltage	Capacity	Capacity Com rtment	Wattage	Control Type	Inset Included	Number of Compartments	Temperature	Net Weight	Gross Weight
AT51388	14"	14.2"	63/4"	10 1/2"	6.7Amps	60	120Volts	9qt.	9 qt	600 Watts	Infinite	Yes	1	105-195°	12.08Lbs	14.29Lbs

Model	Width	Depth	Height	Interior Width	Interior Depth	Interior Height	Amps	Hertz	Voltage	wattage	Control Type	Material	Number of Wells	T	Net Weight Gross Weight	Gross Weight
7700	24"	14.6"	9"	12"	20"	6 1/2"	10Amps	60	120 Volts	1500Watts	Infinite	Stainless Steel	1	Adjustable	16.27Lbs	18.47Lbs



Plan View

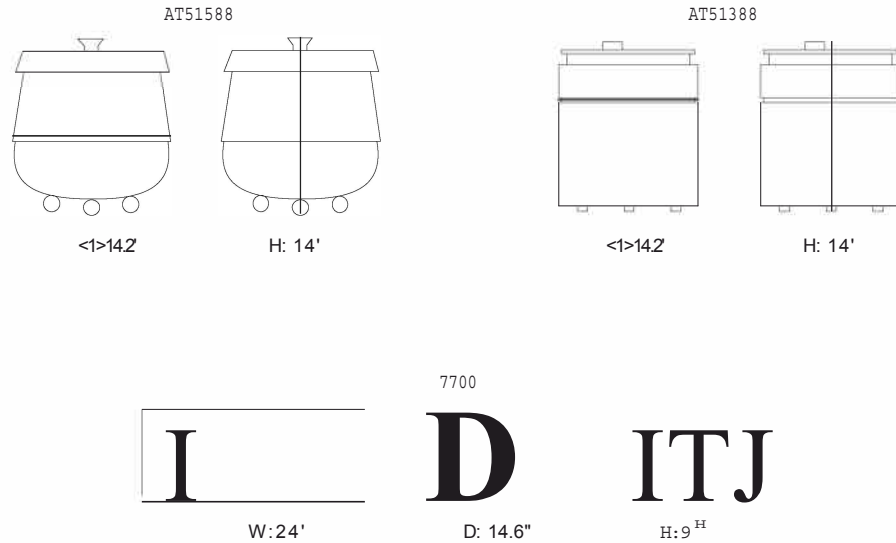

Terms and Conditions

One Year Limited Warranty

Atosa Catering Equipment warrants its equipment against defects in materials and workmanship, subject to the following conditions: Atosa Catering Equipment is warranted for one year, effective from the date of purchase by the original owner. A copy of the original receipt or other proof of purchase is required to obtain warranty coverage. This warranty applies to the original owner only, and is nontransferable. Should any product fail to function in its intended manner under normal use within the limits defined in this warranty, at Atosa's discretion, such product will be replaced with a new unit by Atosa, after defective unit has been inspected. And defect has been confirmed. Atosa does not assume any liability for extended delays in replacing any item beyond its control. This warranty does not apply to plastic and non-metallic synthetic parts that may need to be replaced due to normal usage, or lack of preventative maintenance.

WHAT IS NOT COVERED BY THIS WARRANTY

- Equipment that has not properly been maintained, damage from improper cleaning, and water damage to controls.
- Equipment that has not been used in an appropriate manner, or has been subject to misuse, neglect, abuse, accident, alteration, negligence, damage during transit, fire, flood, or acts of God.

If the equipment has been changed, altered, modified, or repaired without express written permission from Atosa, then the manufacturer shall not be liable for any damages to any person or to any property, which may result from the use of this equipment thereafter.

For warranty and non-warranty related issues, technical support, purchase replacement parts contact Atosa toll free (855) 855-0399

*In some cases, a 25% restocking fee may be charged to a buyer for returned items.

Stainless Steel Equipment Stands

Standard Features

- This stand ships unassembled to save you on shipping cost. Tools are included for easy assembly.
- Its sturdy, stainless steel top surface and undershelf are designed to withstand constant use in your busy commercial kitchen.
- The adjustable undershelf and bullet feet provide additional storage space, as well as optimum stability.
- Safety hemmed edge around the sides and back comes standard to keep equipment and other contents from sliding off.
- Added H-shape reinforced rib underneath the top surface makes it able to support more evenly distributed weight.



ATSE-2824



ATSE-2836



ATSE-2848



Specifications

Model	L(IN)	W(IN)	H(IN)	PACKAGE SIZE (IN)	NET WEIGHT(LBS)	GROSS WEIGHT(LBS)
ATSE-2824	24	28	24	25*29*7	39.7	44
ATSE-2836	36	28	24	37*29*7	53	57.3
ATSE-2848	48	28	24	49*29*7	64	71.6

Plan View

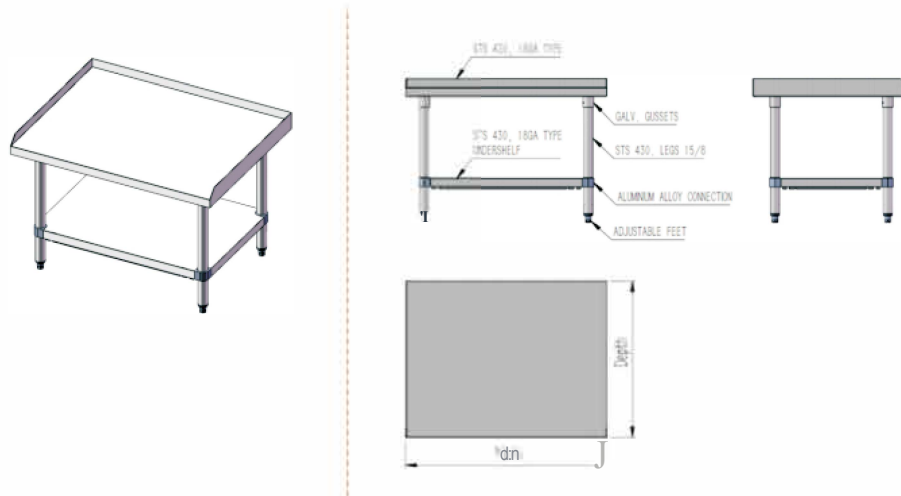

Terms and Conditions

One Year Limited Warranty

Atosa Catering Equipment warrants its equipment against defects in materials and workmanship, subject to the following conditions: Atosa Catering Equipment is warranted for one year, effective from the date of purchase by the original owner. A copy of the original receipt or other proof of purchase is required to obtain warranty coverage. This warranty applies to the original owner only, and is nontransferable. Should any product fail to function in its intended manner under normal use within the limits defined in this warranty, at Atosa's discretion, such product will be replaced with a new unit by Atosa, after defective unit has been inspected. And defect has been confirmed. Atosa does not assume any liability for extended delays in replacing any item beyond its control. This warranty does not apply to plastic and non-metallic synthetic parts that may need to be replaced due to normal usage, or lack of preventative maintenance.

WHAT IS NOT COVERED BY THIS WARRANTY

- Equipment that has not properly been maintained, damage from improper cleaning, and water damage to controls.
- Equipment that has not been used in an appropriate manner, or has been subject to misuse, neglect, abuse, accident, alteration, negligence, damage during transit, fire, flood, or acts of God.

If the equipment has been changed, altered, modified, or repaired without express written permission from Atosa, then the manufacturer shall not be liable for any damages to any person or to any property, which may result from the use of this equipment thereafter.

For warranty and non-warranty related issues, technical support, purchase replacement parts contact Atosa toll free (855) 855-0399

*In some cases, a 25% restocking fee may be charged to a buyer for returned items.

Steam table Pans

Steam table Pans.Stainless Steel



LB

B

DD

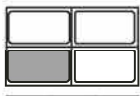
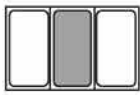

EE§

STEAM TABLE PANS GAUGE24 PRICE LIST

	Model	Size	Depth	Gauge	List
1/1 20-3/4"x12-3/4" 530x325mm	A2001	FULL	1-11/5"	24	NIA
	A2002	FULL	2-1/2"	24	13.00
	A2004	FULL	4"	24	17.66
	A2006	FULL	6"	24	23.40
2/3 13-7/8"x12-3/4" 353x325mm	A2232	TWO THIRDS	2-1/2"	24	NIA
	A2234	TWO THIRDS	4"	24	NIA
	A2236	TWO THIRDS	6"	24	NIA
2/4 20-1/2"x6-3/8" 530x162mm	A2242	TWO FOURTHS	2-1/2"	24	NIA
	A2244	TWO FOURTHS	4"	24	NIA
	A2246	TWO FOURTHS	6"	24	NIA
1/2 12-3/4"x10-3/8" 325x265mm	A2121	HALF	1-11/5"	24	NIA
	A2122	HALF	2-11/2"	24	8.14
	A2124	HALF	4"	24	10.14
	A2126	HALF	6"	24	15.00
1/3 12-3/4"x6-7/8" 325x176mm	A2132	THIRD	2-1/2"	24	6.80
	A2134	THIRD	4"	24	8.26
	A2136	THIRD	6"	24	12.84
1/4 10-3/8"x6-3/8" 265x162mm	A2142	QUARTER	2-11/2"	24	5.18
	A2144	QUARTER	4"	24	7.30
	A2146	QUARTER	6"	24	11.30
1/6 6-7/8"x6-1/4" 176x162mm	A2162	SIXTH	2-1/2"	24	3.98
	A2164	SIXTH	4"	24	6.00
	A2166	SIXTH	6"	24	8.44
1/9 6-7/8"x4-1/4" 176x108mm	A2192	NINTH	2-1/2"	24	3.32
	A2194	NINTH	4"	24	4.10

STEAM TABLE PANS GAUGE22 PRICE LIST

	Model	Size	Depth	Gauge	List
1/1 20-3/4"x12-3/4" 530x325mm	F2001	FULL	1-1/5"	22	NIA
	F2002	FULL	2-11/2"	22	15.98
	F2004	FULL	4"	22	21.04
	F2006	FULL	6"	22	28.18
2/3 13-7/8"x12-3/4" 353x325mm	F2232	TWO THIRDS	2-1/2"	22	NIA
	F2234	TWO THIRDS	4"	22	NIA
	F2236	TWO THIRDS	6"	22	NIA
2/4 20-1/2"x6-3/8" 530x162mm	F2242	TWO FOURTHS	2-1/2"	22	NIA
	F2244	TWO FOURTHS	4"	22	NIA
	F2246	TWO FOURTHS	6"	22	NIA
1/2 12-3/4"x10-3/8" 325x265mm	F2121	HALF	1-1/5"	22	NIA
	F2122	HALF	2-11/2"	22	9.94
	F2124	HALF	4"	22	12.30
	F2126	HALF	6"	22	17.78
1/3 12-3/4"x6-7/8" 325x176mm	F2132	THIRD	2-1/2"	22	8.28
	F2134	THIRD	4"	22	10.20
	F2136	THIRD	6"	22	15.48
1/4 10-3/8"x6-3/8" 265x162mm	F2142	QUARTER	2-1/2"	22	6.64
	F2144	QUARTER	4"	22	8.86
	F2146	QUARTER	6"	22	13.62
1/6 6-7/8"x6-1/4" 176x162mm	F2162	SIXTH	2-1/2"	22	4.92
	F2164	SIXTH	4"	22	7.12
	F2166	SIXTH	6"	22	10.30
1/9 6-7/8"x4-1/4" 176x108mm	F2192	NINTH	2-1/2"	22	4.10
	F2194	NINTH	4"	22	5.12

D

LB



DD

ODD



BEE

EE§

(MIXrICE)

"MAKE THE STEEL RITE !"



LIDS PRICE

		Model	Size	TYPE	Gauge	List
1/1	20-3/4"x12-3/4" 530x325mm	A1000C	FULL	SOLID	24	12.96
		A1000CS	FULL	SLOTIED	24	12.96
2/3	13-7/8"x12-3/4" 353x325mm	A1230C	TWO THIRDS	SOLID	24	N/A
		A1230CS	TWO THIRDS	SLOTIED	24	N/A
2/4	20-1/2"x6-3/8" 530x162mm	A1240C	TWO FOURTHS	SOLID	24	N/A
		A1240CS	TWO FOURTHS	SLOTIED	24	N/A



Perforated Steam Table Pans. Stainless Steel

LIDS PRICE

		Model	Size	TYPE	Gauge	List
1/2	12-3/4"x10-3/8" 325x265mm	All20C	HALF	SOLID	24	6.66
		All20CS	HALF	SLOTIED	24	6.66
1/3	12-3/4"x6-7/8" 325x176mm	All30C	THIRD	SOLID	24	4.98
		All30CS	THIRD	SLOTIED	24	4.98
1/4	10-3/8"x6-3/8" 265x162mm	All40C	QUARTER	SOLID	24	4.60
		All40CS	QUARTER	SLOTIED	24	4.60
1/6	6-7/8"x6-1/4" 176x162mm	All60C	SIXTH	SOLID	24	3.14
		All60CS	SIXTH	SLOTIED	24	3.14
1/9	6-7/8"x4-1/4" 176x108mm	All90C	NINTH	SOLID	24	2.70
		All90CS	NINTH	SLOTIED	24	2.70

PERFORATED PANS PRICE

		Model	Size	Depth	Gauge	List
1/1	20-3/4"x12-3/4" 530x325mm	A2001P	FULL	1-1/5"	24	N/A
		A2002P	FULL	2-1/2"	24	17.36
		A2004P	FULL	4"	24	24.18
		A2006P	FULL	6"	24	31.56
1/2	12-3/4"x10-3/8" 325x265mm	A2121P	HALF	1-1/5"	24	N/A
		A2122P	HALF	2-1/2"	24	10.36
		A2124P	HALF	4"	24	12.28
		A2126P	HALF	6"	24	18.7
1/1	20-3/4"x12-3/4" 530x325mm	F2001P	FULL	1-1/5"	22	N/A
		F2002P	FULL	2-1/2"	22	20.64
		F2004P	FULL	4"	22	27.90
		F2006P	FULL	6"	22	37.10
1/2	12-3/4"x10-3/8" 325x265mm	F2121P	HALF	1-1/5"	22	N/A
		F2122P	HALF	2-1/2"	22	12.56
		F2124P	HALF	4"	22	14.86
		F2126P	HALF	6"	22	22.02



(MIXrICE)

MixRite offers high quality stainless steel products. The products in this line are made for every day use, but are designed with exceptional craftsmanship. Our sinks are formed from a single sheet, fused and polished creating a one-piece sanitary unit. Just like the other Atosa products, MixRite offers a cosmetically beautiful appearance. This lines consists of food pans, work tables, equipment stands, and sinks.



SINKS & TABLES

Work Tables 24 inch Series	47
Work Tables 30 inch Series	48
Compartment Sinks MRSA-1-D	49
Compartment Sinks MRSA-1-L	50
Compartment Sinks MRS-1-MOP	51
Compartment Sinks MRSA-1-N	52
Compartment Sinks MRSA-1-R	53
Compartment Sinks MRSB-3-D/MRSA-3-D	54
Welding Hand Wash Sinks MRS-HS-14	55
Welding Hand Wash Sinks MRS-HS-18	56

(MIXrICE)

MAKE THE STEEL RITE !

Toll Free:855-855-0399 Email:info@atosausa.com
www.atosa.com |www.atosausa.com



SINKS & TABLES

California, Colorado, Florida, Georgia, Illinois, Massachusetts, New Jersey, Ohio, Texas,
Washington

Work Tables 24 inch Series



Standard Features

- 18 GA Stainless steel top reinforced with a welded channel frame
- Entire top mechanically polished to a satin finish
- Top is sound deadened
- All edges are turned down as a safety feature
- Galvanized tubular legs and under shelf are standard features on all models
- Under shelf can be adjusted to desired height
- Adjustable bullet feet
- Ships K.D
- Easy to assemble



Specifications (unit:inch)

Model	Ga.	L	D	H	Net Weight (lbs.)
MRIW-2424	18	24	24	34	31
MRIW-2430	18	30	24	34	37
MRIW-2436	18	36	24	34	42
MRIW-2448	18	48	24	34	52
MRIW-2460	18	60	24	34	66
MRIW-2472	18	72	24	34	80

Plan View

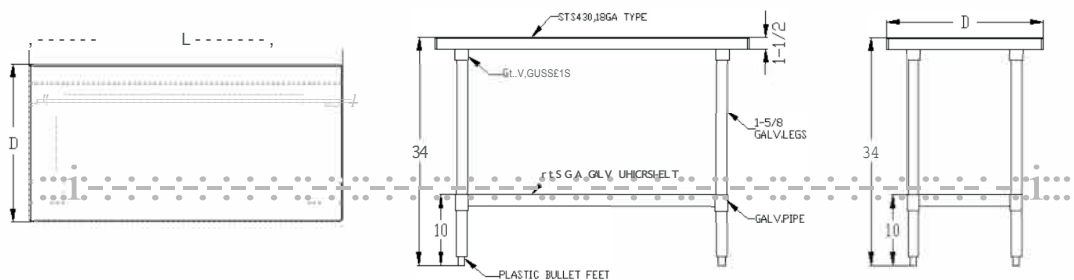

Work Tables 30 inch Series



Standard Features

- 18 GA stainless steel top reinforced with a welded channel frame
- Entire top mechanically polished to a satin finish
- Top is sound deadened
- All edges are turned down as a safety feature
- Galvanized tubular legs and under shelf are standard features on all models
- Under shelf can be adjusted to desired height
- Adjustable bullet feet
- Ships K.D
- Easy to assemble



Specifications (unit:inch)

Model	Ga.	L	D	H	Net Weight (lbs.)
MRIW-3030	18	30	30	34	42
MRIW-3036	18	36	30	34	48
MRIW-3048	18	48	30	34	59
MRIW-3060	18	60	30	34	74
MRIW-3072	18	72	30	34	90
MRIW-3084	18	84	30	34	102
MRIW-3096	18	96	30	34	117

Plan View

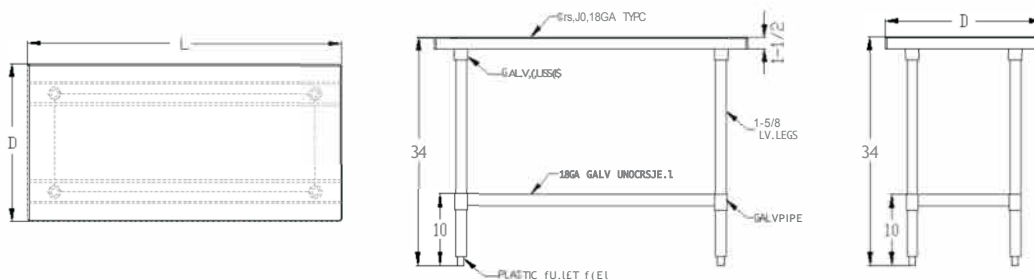

Compartment Sinks MRSA-1-D



Standard Features

- Entire sink is formed from a single sheet, fused and polished creating a one-piece sanitary unit
- All exposed welds are grounded smooth and polished to blend with adjacent surfaces providing a satin finish
- Large radius on all comers both vertically and horizontally
- Creased and angled drain boards for easy drainage
- Galvanized legs are standard on all models
- Adjustable ABS bullet feet
- Faucets sold separately



Specifications (unit:inch)

Model	Ga.	Bowl Size (L X O' X H")	Length(L)	Depth(D)	Height(H)	Leg(A)	Net Weight (lbs.)
MRSA-1-0	18	18X18X12	54	24	44 12	22 12	45

Plan View

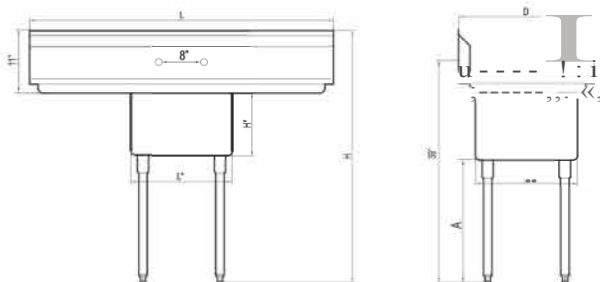

11=X=11

(unit : inch)

Compartment Sinks MRSA-1-L



Standard Features

- Entire sink is formed from a single sheet, fused and polished creating a one-piece sanitary unit
- All exposed welds are grounded smooth and polished to blend with adjacent surfaces providing a satin finish
- Large radius on all comers both vertically and horizontally
- Creased and angled drain boards for easy drainage
- Galvanized legs are standard on all models
- Adjustable ABS bullet feet
- Faucets sold separately



Specifications (unit:inch)

Model	Ga.	Bowl Size (L•X o•X H")	Length(L)	Depth(D)	Height(H)	Leg(A)	Net Weight (lbs.)
MRSA-1-L	18	18X18X12	39	24	44 12	22 12	39

Plan View

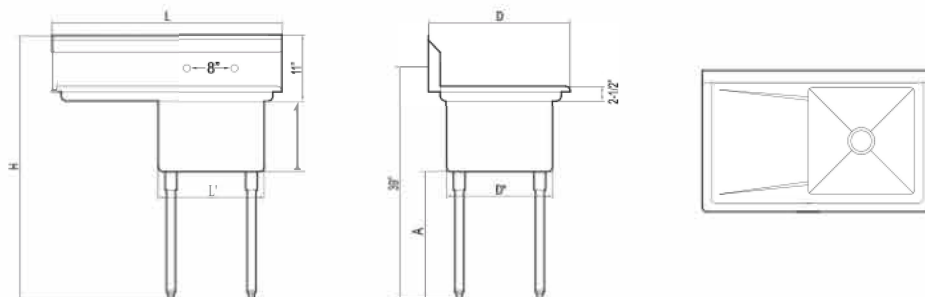

Compartment Sinks MRS-1-MOP



Standard Features

- Entire sink is formed from a single sheet, fused and polished creating a one-piece sanitary unit
- All exposed welds are grounded smooth and polished to blend with adjacent surfaces providing a satin finish
- Large radius on all comers both vertically and horizontally
- Creased and angled drain boards for easy drainage
- Galvanized legs are standard on all models
- Adjustable ABS bullet feet
- Faucets sold separately



Specifications (unit:inch)

Model	Ga.	Bowl Size (L x O x H")	Length(L)	Depth(D)	Height(H)	Leg(A)	Net Weight (lbs.)
MRS-1-MOP	18	18X18X13	21	21 1/2	44 1/2	20 1/2	30

Plan View

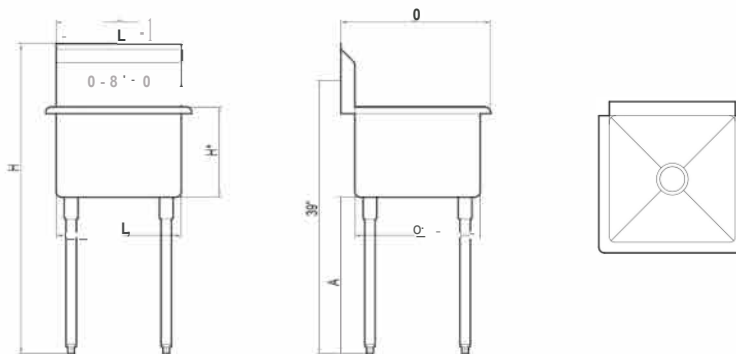

Compartment Sinks MRSA-1-N



Standard Features

- Entire sink is formed from a single sheet, fused and polished creating a one-piece sanitary unit
- All exposed welds are grounded smooth and polished to blend with adjacent surfaces providing a satin finish
- Large radius on all comers both vertically and horizontally
- Creased and angled drain boards for easy drainage
- Galvanized legs are standard on all models
- Adjustable ABS bullet feet
- Faucets sold separately



Specifications (unit:inch)

Model	Ga.	Bowl Size (L×Xo×XH")	Length(L)	Depth(D)	Height(H)	Leg(A)	Net Weight (lbs.)
MRSA-1-N	18	18X18X12	24	24	44 12	21 12	30

Plan View

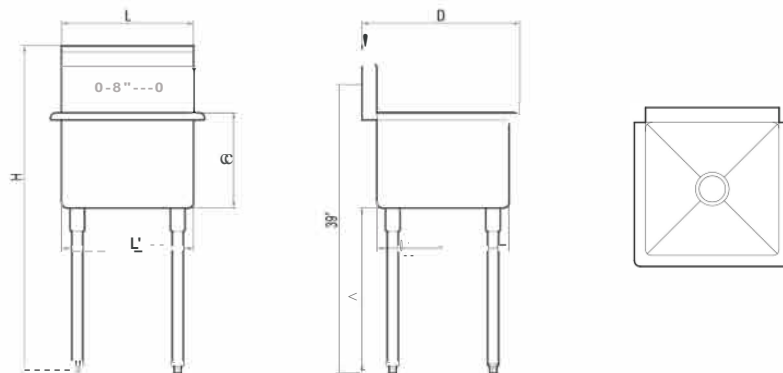

Compartment Sinks MRSA-1-R



Standard Features

- Entire sink is formed from a single sheet, fused and polished creating a one-piece sanitary unit
- All exposed welds are grounded smooth and polished to blend with adjacent surfaces providing a satin finish
- Large radius on all comers both vertically and horizontally
- Creased and angled drain boards for easy drainage
- Galvanized legs are standard on all models
- Adjustable ABS bullet feet
- Faucets sold separately



Specifications (unit:inch)

Model	Ga.	Bowl Size (L•Xo•XH")	Length(L)	Depth(D)	Height(H)	Leg(A)	Net Weight (lbs.)
MRSA-1-R	18	18X18X12	39	24	44 1/2	22 1/2	39

Plan View

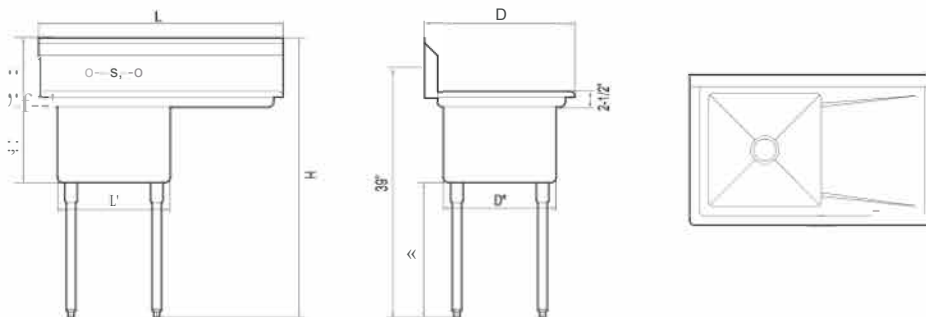

Compartment Sinks MRSB-3-D/MRSA-3-D



Standard Features

- Entire sink is formed from a single sheet, fused and polished creating a one-piece sanitary unit
- All exposed welds are grounded smooth and polished to blend with adjacent surfaces providing a satin finish
- Large radius on all comers both vertically and horizontally
- Creased and angled drain boards for easy drainage
- Galvanized legs are standard on all models
- Adjustable ABS bullet feet
- Faucets sold separately



Specifications (unit:inch)

Model	Ga.	Bowl Size (L X O X H")	Length(L)	Depth(D)	Height(H)	Leg(A)	Net Weight (lbs.)
MRSB-3-0	16	24X24X14	120	30	44 1/2	19 1/2	161
MRSA-3-D	18	18X18X12	90	24	44 1/2	21 1/2	84

Plan View

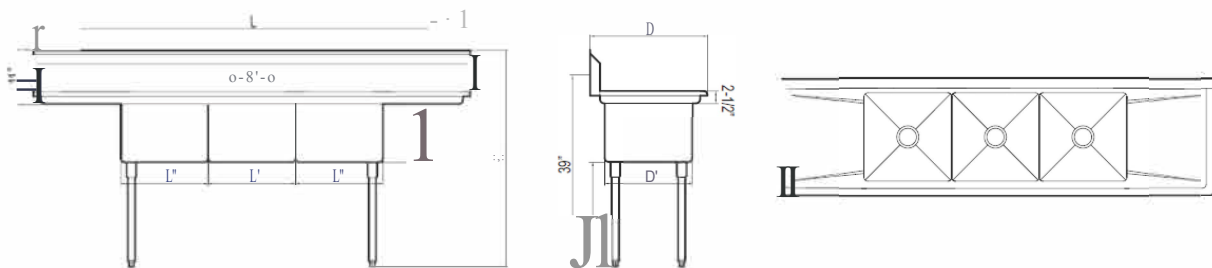

Welding Hand Wash Sinks MRS-HS-14



Standard Features

- 18 Gauge, 300 series stainless steel
- 6" Backsplash with 2" return
- Goose neck faucet included
- 1-1/2" Drain opening
- 1-1/8" faucet holes on 4" centers
- 1-1/2" waste drain opening
- Strainer and faucet included
- Z-clip mounting bracker
- Easy to clean and sanitize



Options

- Side Splashes
- Faucet Upgrade

Specifications (unit:inch)

Model	Ga.	Bowl Size (L*XD*XH')	Length(L)	Depth(D)	Height(H)	NetWeight (lbs.)
MRS-HS-14	18	10X12X5	14	16 12	11	12

Plan View

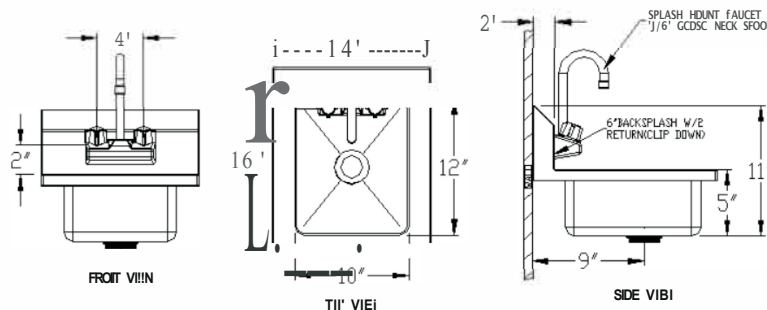

Welding Hand Wash Sinks MRS-HS-18



Standard Features

- 18 Gauge, 300 series stainless steel
- 6" Backsplash with 2" return
- Goose neck faucet included
- 1-1/2" Drain opening
- 1-1/8" faucet holes on 4" centers
- 1-1/2" waste drain opening
- Strainer and faucet included
- Z-clip mounting bracker
- Easy to clean and sanitize



Options

- Side Splashes
- Faucet Upgrade

Specifications (unit:inch)

Model	Ga.	Bowl Size (L*XD*XH')	Length(L)	Depth(D)	Height(H)	Net Weight (lbs.)
MRS-HS-18	18	14X10X5	18	14 1/2	11	13

Plan View

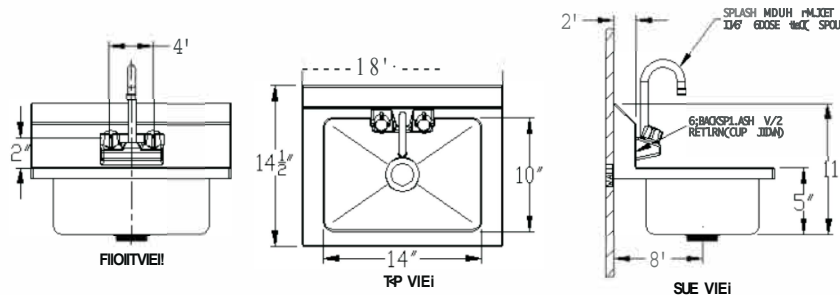

OUR BRANDS

We Make The Kitchen Better



WE ARE THE SPECICOOOLIST!

Cuah.711te.

TO COOK NICELY!

iwPaO

YOUR KITCHEN PAL!

(M1xnce)

MAKE THE STEEL RITE!

We Make The Kitchen Better



ATOSA Catering Equipment INC.

Toll Free: 855-855-0399 Email: info@atosausa.com

www.atosa.com | www.atosausa.com

California, Colorado, Florida, Georgia, Illinois, Massachusetts, New Jersey, Ohio, Texas, Washington



Version: C2017-1